

Yêu cầu:

				Project	
				Drawing No.	
				Part name	
				BT TAI BÈO W500-H1166-L5320	
				Material	Qty
				Scale	
APPV'D					

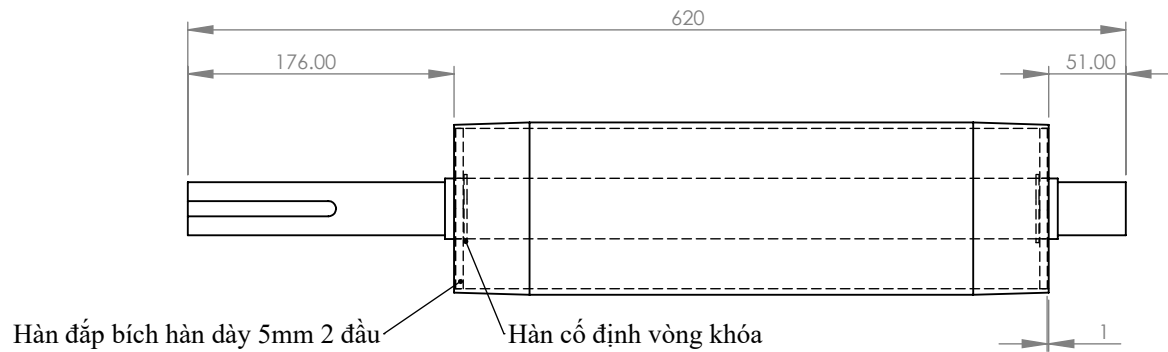

Hàn đắp bích hàn dày 5mm 2 đầu

Hàn cố định vòng khóa

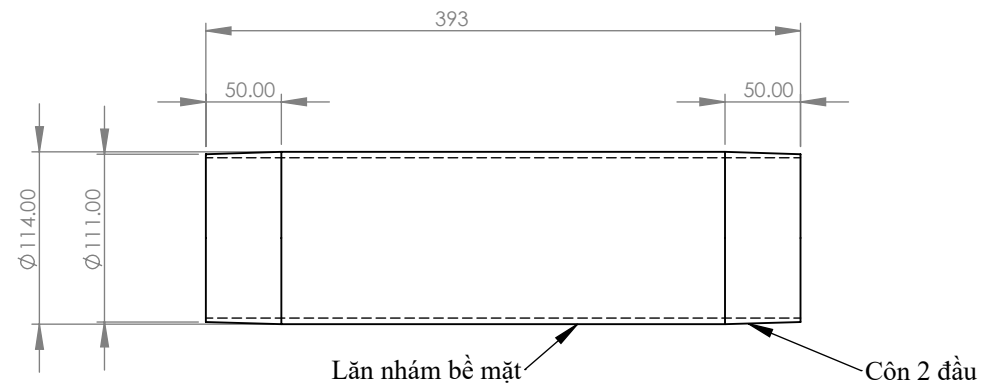

Lăn nhám bề mặt

Côn 2 đầu

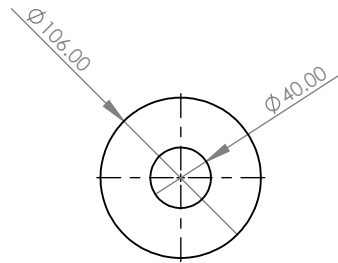

BÍCH HÀN ROLLER CHỦ ĐỘNG

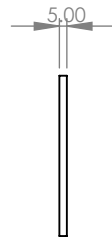

Yêu cầu: Sử dụng ống thép D114 dày 4mm

 <b>AKIA VIET NAM</b>				Project	
				Drawing No.	
<b>CON LĂN CHỦ ĐỘNG</b>				Part name	
				Material	
DRAWN		K.C.Khanh		SS400	
CHECK'D		P.V.Thành		Scale 1:5	
APPV'D				Q.ty 1	

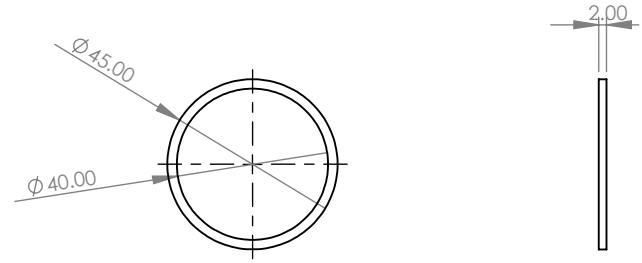
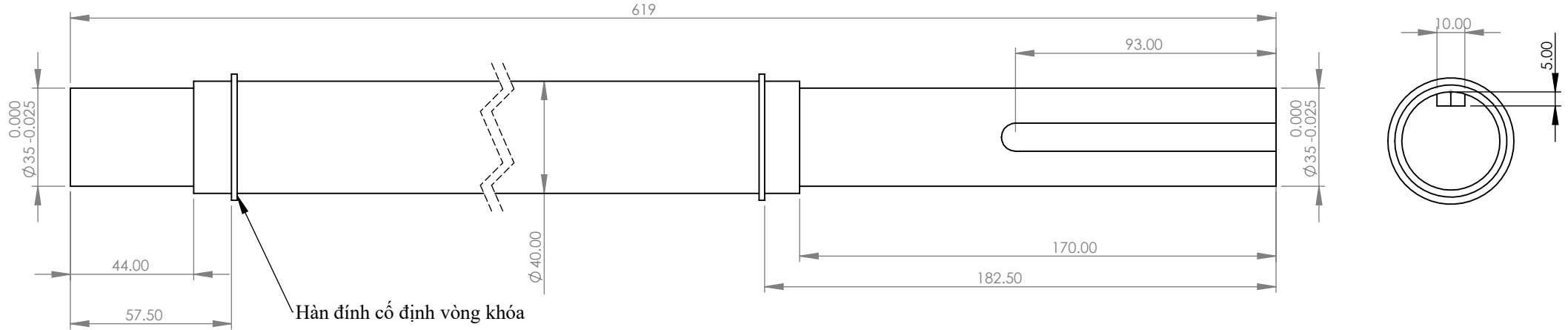

VÒNG KHÓA TRỤC CHỦ ĐỘNG

Yêu cầu:

				Project	
				Drawing No.	
<b>TRỤC CHỦ ĐỘNG</b>				Part name	
				Material	
A4		NAME		SS400	
DRAWN		SIGNATURE		Q.ty	
K.C.Khanh		DATE		Scale	
P.V.Thành				1:2	
APPV'D				I	

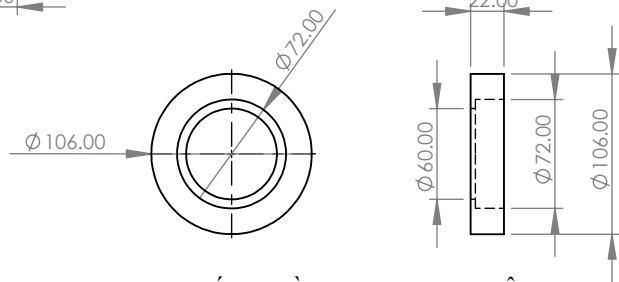
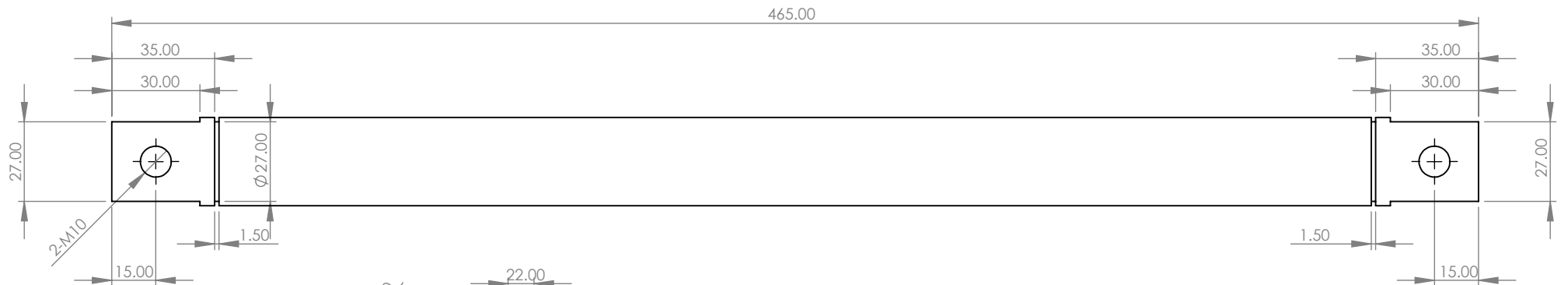

BÍCH HÀN ROLLER BỊ ĐỘNG

Yêu cầu:

				Project	
				Drawing No.	
Part name				CON LĂN BỊ ĐỘNG	
Material				SS400	Qty
Scale				1:2	1
APPV'D					

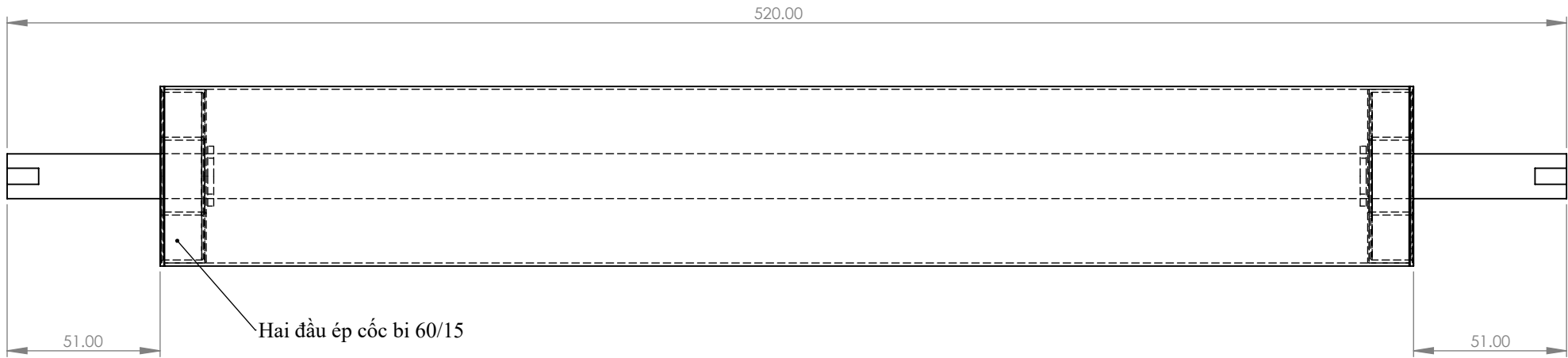

Yêu cầu:

 <b>AKIA VIET NAM</b>				Project							
				Drawing No.							
<table border="1"> <tr> <td colspan="2">Part name</td> </tr> <tr> <td colspan="2" style="text-align: center;"><b>CON LĂN ÉP CỐC BI</b></td> </tr> </table>				Part name		<b>CON LĂN ÉP CỐC BI</b>		Material			
				Part name							
<b>CON LĂN ÉP CỐC BI</b>											
<table border="1"> <tr> <td colspan="2" style="text-align: center;"><b>SUS304</b></td> <td>Qty</td> </tr> <tr> <td colspan="2" style="text-align: center;">Scale 1:2</td> <td style="text-align: center;">2</td> </tr> </table>				<b>SUS304</b>		Qty	Scale 1:2		2		
				<b>SUS304</b>		Qty					
Scale 1:2		2									
A4	NAME	SIGNATURE	DATE								
DRAWN	K.C.Khanh										
CHEK'D	P.V.Thành										
APPV'D											

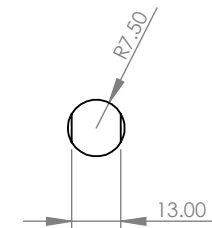
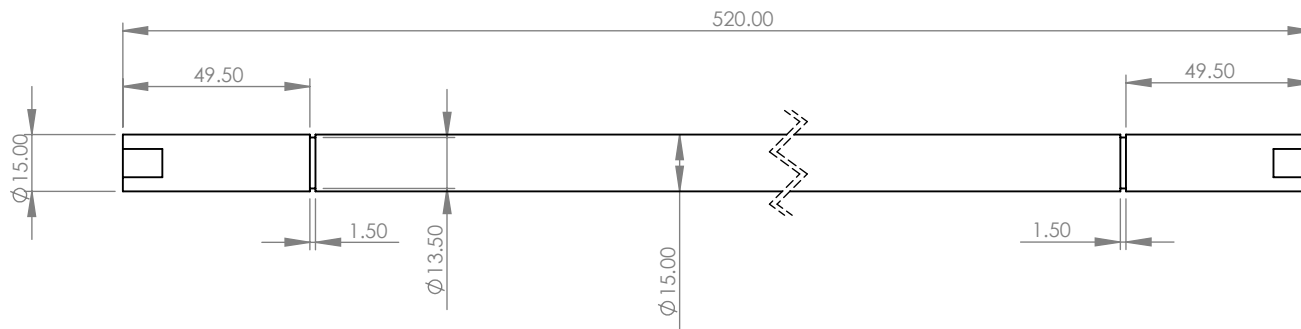

Yêu cầu:

 <b>AKIA VIET NAM</b>				<i>Project.</i>							
				<i>Drawing No.</i>							
<table border="1"> <tr> <td colspan="2"><i>Part name.</i></td> </tr> <tr> <td colspan="2">TRỤC CON LẤN ÉP CỐC BI</td> </tr> </table>				<i>Part name.</i>		TRỤC CON LẤN ÉP CỐC BI		<i>Material.</i>			
				<i>Part name.</i>							
TRỤC CON LẤN ÉP CỐC BI											
<table border="1"> <tr> <td colspan="2">SS400</td> <td><i>Q.ty</i></td> </tr> <tr> <td colspan="2">Scale 1:2</td> <td>2</td> </tr> </table>				SS400		<i>Q.ty</i>	Scale 1:2		2		
				SS400		<i>Q.ty</i>					
Scale 1:2		2									
<i>A4</i>	<i>NAME</i>	<i>SIGNATURE</i>	<i>DATE</i>								
DRAWN	K.C.Khanh										
CHEK'D	P.V.Thành										
APPV'D											

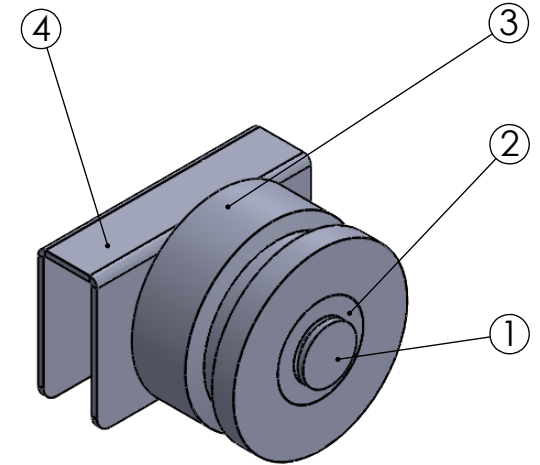
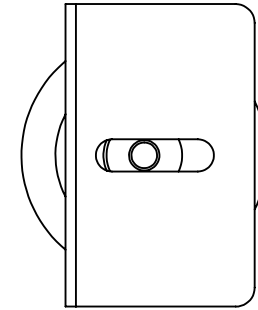
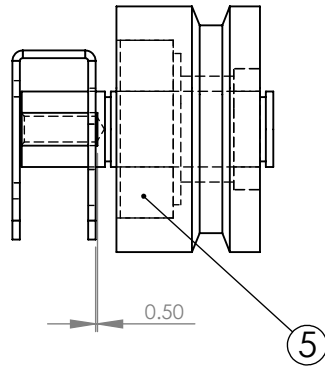
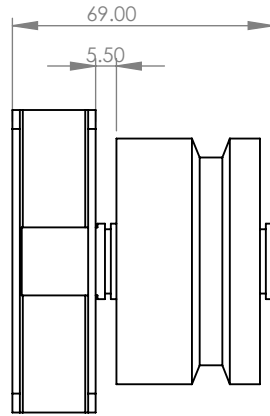

5	Ó BÍ 6204ZZ	AKIA	1			
4	BÍCH GÁ CON LĂN TỶ BELT TRÊN	AKIA	1	SS400		
3	CON LĂN TỶ BELT	AKIA	1	Nhựa POM		
2	Ó BÍ 6804ZZ	AKIA	1			
1	TRỤC CON LĂN TỶ BELT	AKIA	1	SS400		
<i>No</i>	<i>Part name</i>	<i>Maker</i>	<i>Qty</i>	<i>Material</i>	<i>Part code</i>	<i>Specification</i>

**PART LIST**

				<i>Project</i>	
				<i>Drawing No.</i>	
<b>CỤM CON LĂN TỶ BELT TRÊN</b>				<i>Part name</i>	
				<i>Material</i>	
<i>A4</i>	<i>NAME</i>	<i>SIGNATURE</i>	<i>DATE</i>	<i>Scale</i>	
DRAWN	K.C.Khanh			1:2	
CHEK'D	P.V.Thành			14	
APPV'D					

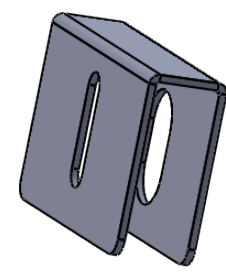
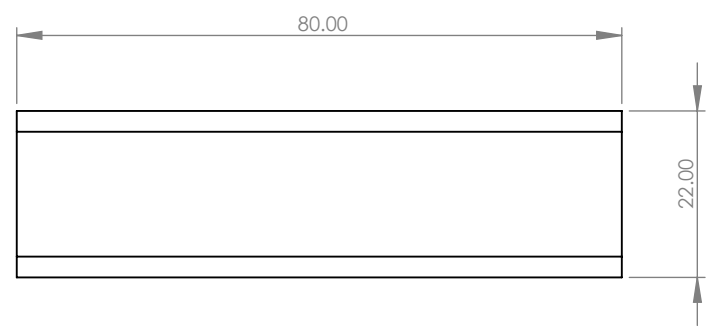
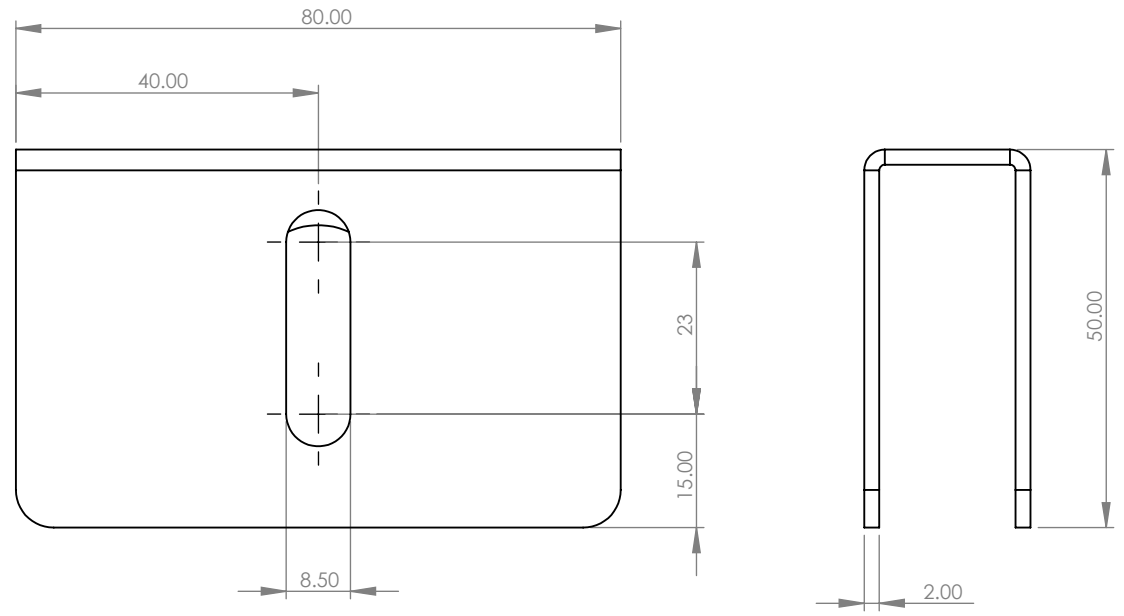
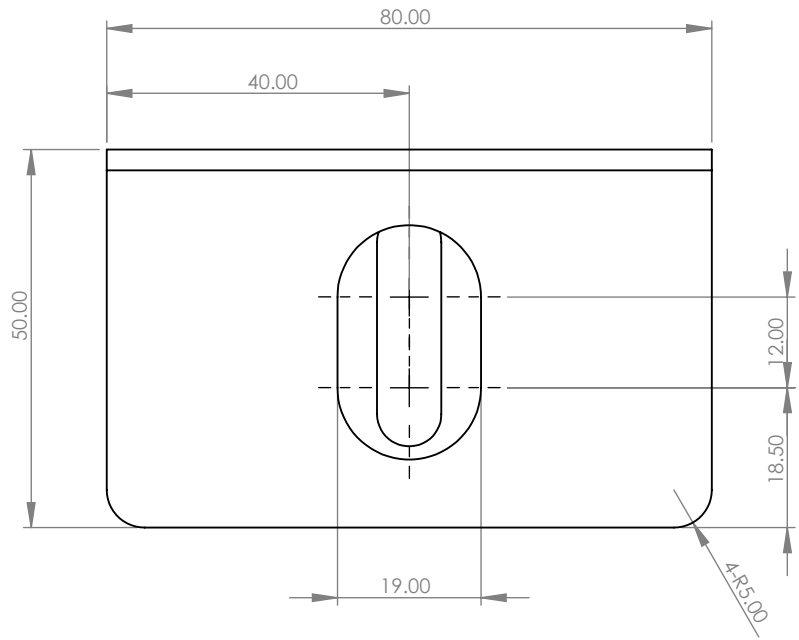

Yêu cầu:

 <b>AKIA VIET NAM</b>				Project										
				Drawing No.										
<table border="1"> <tr> <td>Part name</td> <td colspan="2"><b>BÍCH GÁ CON LẮN TỶ BELT TRÊN</b></td> </tr> <tr> <td>Material</td> <td><b>SS400</b></td> <td>Qty</td> </tr> <tr> <td>Scale</td> <td><b>1:1</b></td> <td><b>14</b></td> </tr> </table>				Part name	<b>BÍCH GÁ CON LẮN TỶ BELT TRÊN</b>		Material	<b>SS400</b>	Qty	Scale	<b>1:1</b>	<b>14</b>	Material	
				Part name	<b>BÍCH GÁ CON LẮN TỶ BELT TRÊN</b>									
Material	<b>SS400</b>	Qty												
Scale	<b>1:1</b>	<b>14</b>												
DRAWN		K.C.Khanh		Material										
CHECK'D		P.V.Thành		Qty										
APPV'D				Scale										
				1:1										
				14										



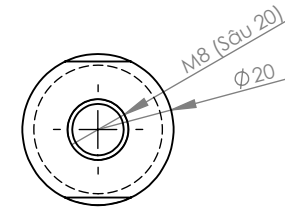
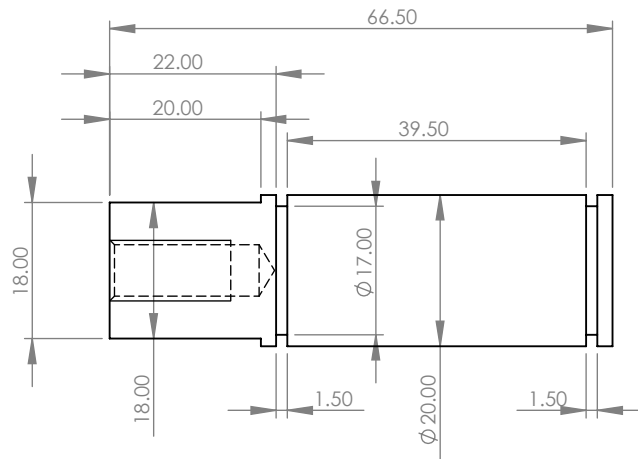

Yêu cầu:

 <b>AKIA VIET NAM</b>				<i>Project.</i>	
				<i>Drawing No.</i>	
				<i>Part name.</i>	
				TRỤC CON LẤN TỶ BELT TRÊN	
<i>A4</i>	<i>NAME</i>	<i>SIGNATURE</i>	<i>DATE</i>	<i>Material.</i>	
DRAWN	K.C.Khanh			SS400	Q.ty
CHEK'D	P.V.Thành			Scale 1:1	14
APPV'D					

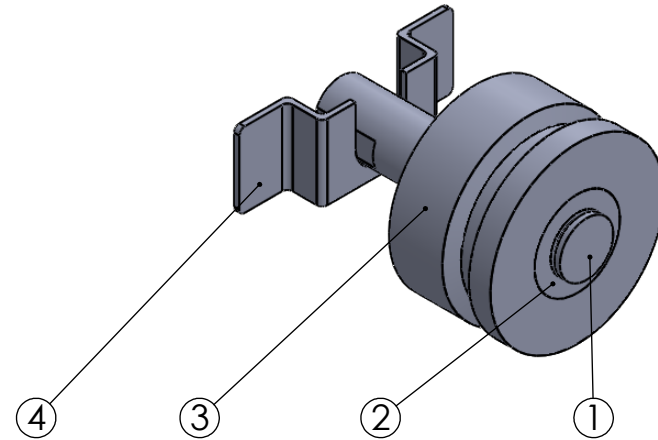
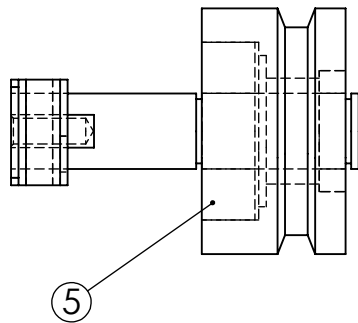
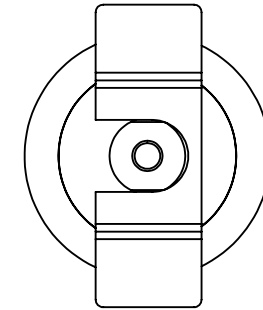
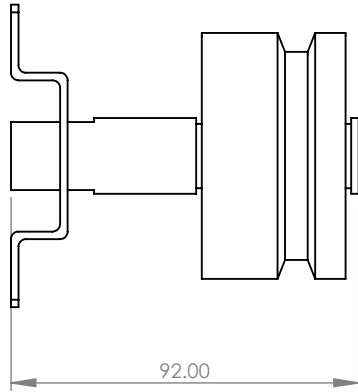

5	Ó BÌ 6204ZZ	AKIA	1			
4	BÍCH GÁ CON LĂN TỶ BELT DƯỚI	AKIA	1	SS400		
3	CON LĂN TỶ BELT	AKIA	1	Nhựa POM		
2	Ó BÌ 6804ZZ	AKIA	1			
1	TRỤC CON LĂN TỶ BELT DƯỚI	AKIA	1	SS400		
<i>No</i>	<i>Part name</i>	<i>Maker</i>	<i>Qty</i>	<i>Material</i>	<i>Part code</i>	<i>Specification</i>

**PART LIST**

				<i>Project</i>	
				<i>Drawing No.</i>	
<b>CON LĂN TỶ BELT DƯỚI</b>				<i>Part name</i>	
				<i>Material</i>	
<i>A4</i>	<i>NAME</i>	<i>SIGNATURE</i>	<i>DATE</i>	<i>Scale</i>	
DRAWN	K.C.Khanh				
CHEK'D	P.V.Thành			1:2	
APPV'D					

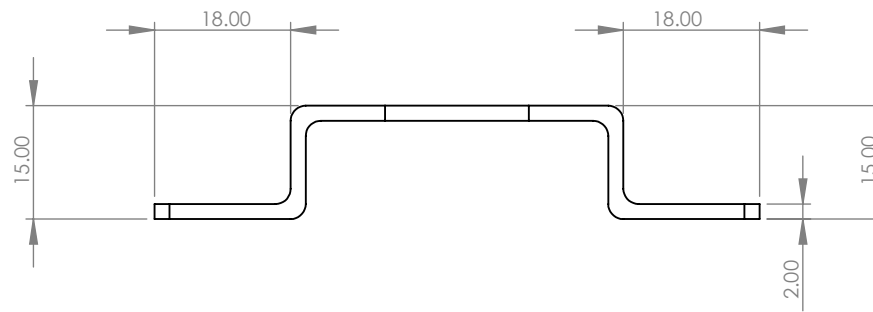
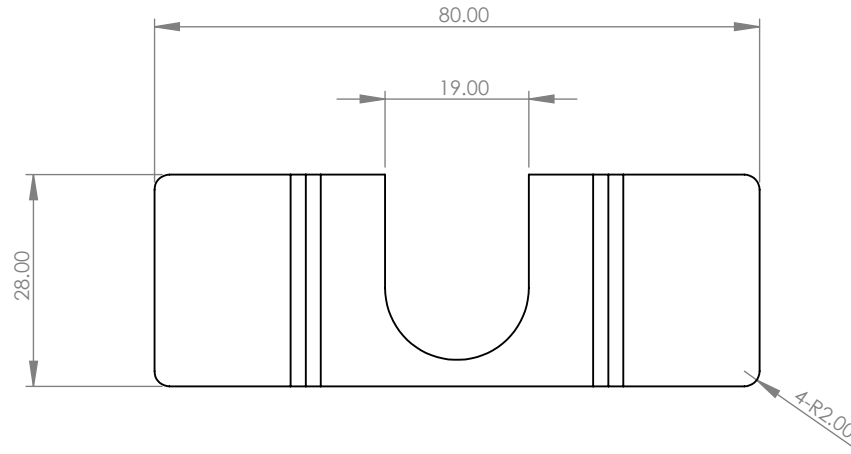

Yêu cầu: dày 2mm

 <b>AKIA VIET NAM</b>				Project							
				Drawing No.							
<table border="1"> <tr> <td colspan="2">Part name</td> </tr> <tr> <td colspan="2" style="text-align: center;"><b>BÍCH CON LẤN TỶ BELT DƯỚI</b></td> </tr> </table>				Part name		<b>BÍCH CON LẤN TỶ BELT DƯỚI</b>		Material			
				Part name							
<b>BÍCH CON LẤN TỶ BELT DƯỚI</b>											
<table border="1"> <tr> <td colspan="2">SS400</td> <td>Qty</td> </tr> <tr> <td colspan="2">Scale 1:1</td> <td>18</td> </tr> </table>				SS400		Qty	Scale 1:1		18		
				SS400		Qty					
Scale 1:1		18									
A4	NAME	SIGNATURE	DATE								
DRAWN	K.C.Khanh										
CHEK'D	P.V.Thành										
APPV'D											

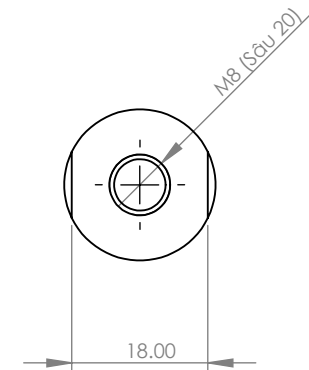
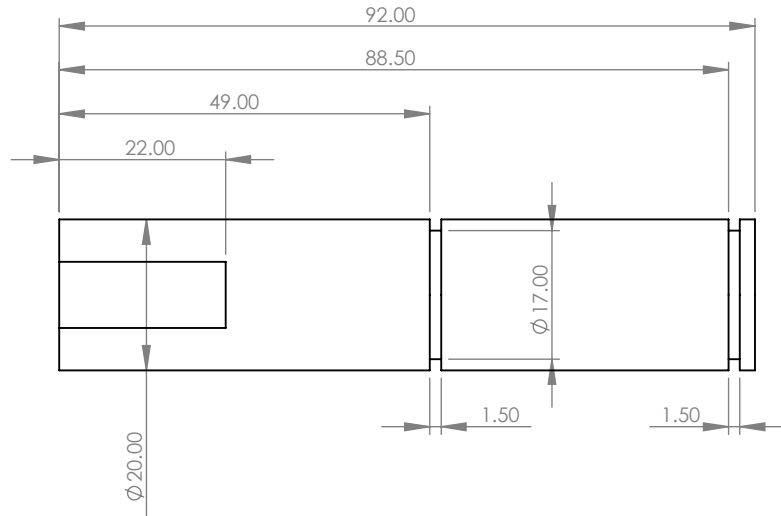

Yêu cầu:

 <b>AKIA VIET NAM</b>				<i>Project.</i>																	
				<i>Drawing No.</i>																	
<table border="1"> <thead> <tr> <th><i>A4</i></th> <th><i>NAME</i></th> <th><i>SIGNATURE</i></th> <th><i>DATE</i></th> </tr> </thead> <tbody> <tr> <td><i>DRAWN</i></td> <td><i>K.C.Khanh</i></td> <td></td> <td></td> </tr> <tr> <td><i>CHEK'D</i></td> <td><i>P.V.Thành</i></td> <td></td> <td></td> </tr> <tr> <td><i>APPV'D</i></td> <td></td> <td></td> <td></td> </tr> </tbody> </table>				<i>A4</i>	<i>NAME</i>	<i>SIGNATURE</i>	<i>DATE</i>	<i>DRAWN</i>	<i>K.C.Khanh</i>			<i>CHEK'D</i>	<i>P.V.Thành</i>			<i>APPV'D</i>				<i>Part name.</i>	
				<i>A4</i>	<i>NAME</i>	<i>SIGNATURE</i>	<i>DATE</i>														
<i>DRAWN</i>	<i>K.C.Khanh</i>																				
<i>CHEK'D</i>	<i>P.V.Thành</i>																				
<i>APPV'D</i>																					
				<b>TRỤC CON LẤN TỶ BELT DƯỚI</b>																	
				<i>Material.</i>																	
				<b>SS400</b>		<i>Q.ty</i>															
				<i>Scale</i>																	
				<b>1:1</b>																	
				<b>18</b>																	

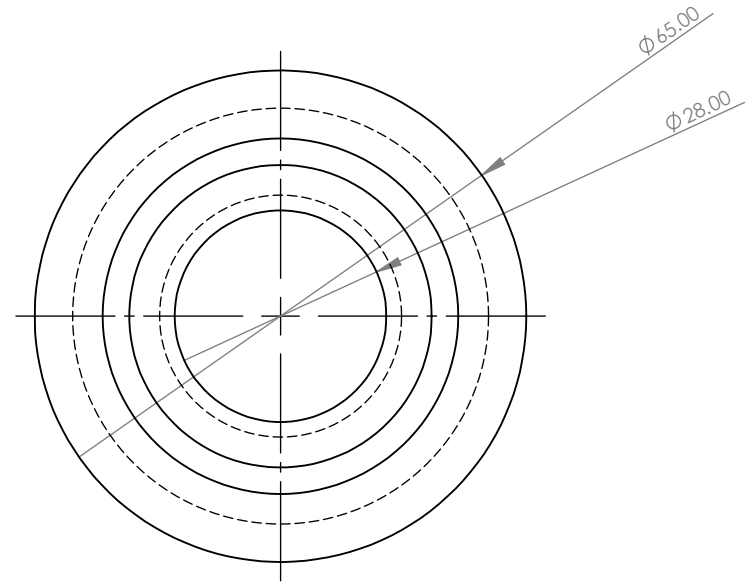
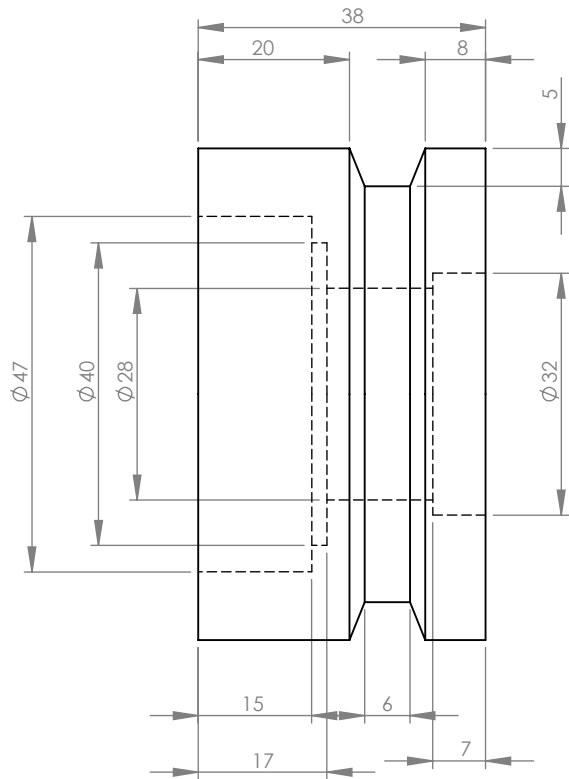

Yêu cầu:

 <b>AKIA VIET NAM</b>				<i>Project</i>	
				<i>Drawing No.</i>	
<b>CON LẮN TỶ BELT</b>				<i>Part name</i>	
				<i>Material</i>	
<i>A4</i>	<i>NAME</i>	<i>SIGNATURE</i>	<i>DATE</i>	Nhựa POM	<i>Q.ty</i> 32
DRAWN	K.C.Khanh				
CHEK'D	P.V.Thành			Scale 1:2	
APPV'D					

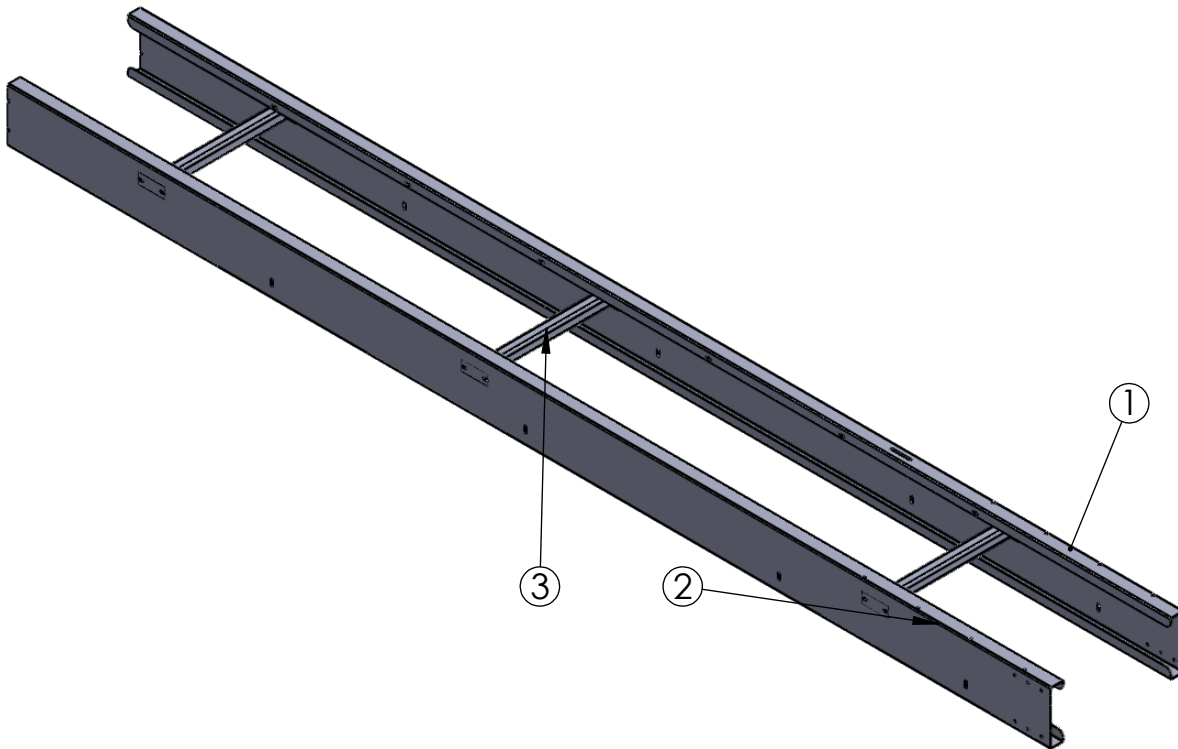
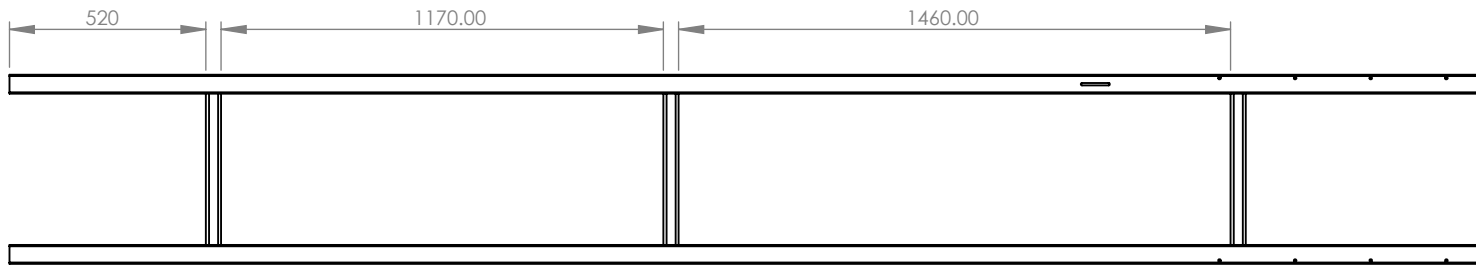
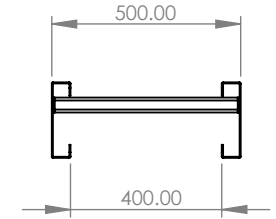
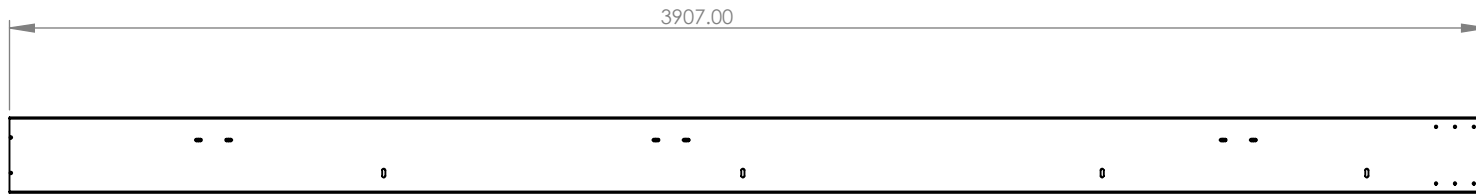

2	CUM THANH GIANG BANG TAI	AKIA	3		
2	VAI BANG TAI 1-2	AKIA	1		
1	VAI BANG TAI 1-1	AKIA	1		
No	Part name	Maker	Qty	Part code	Specification

**PART LIST**

				Project	
				Drawing No.	
<b>KHUNG NGANG 1(BT W500-L5230-H1166)</b>				Part name	
				Material	
<b>A4</b> DRAWN K.C.Khanh CHEK'D P.V.Thành APPV'D	<b>NAME</b> K.C.Khanh P.V.Thành	<b>SIGNATURE</b>  	<b>DATE</b>  	<b>Material</b> SS400 Scale 1:20	<b>Qty</b> 1



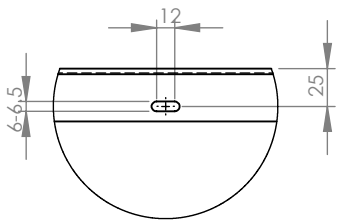
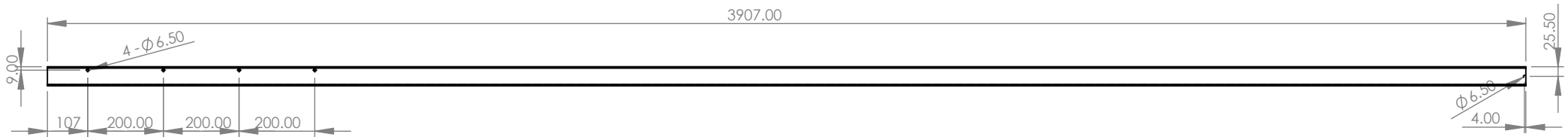
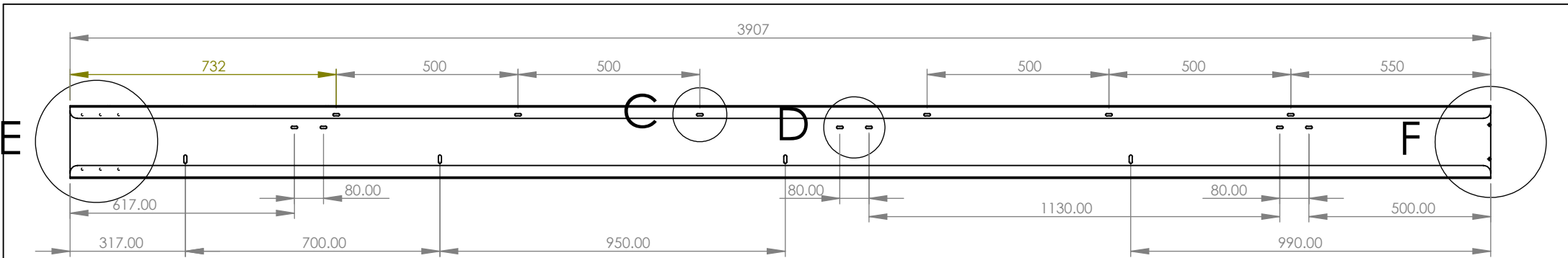

DETAIL C  
SCALE 1 : 5

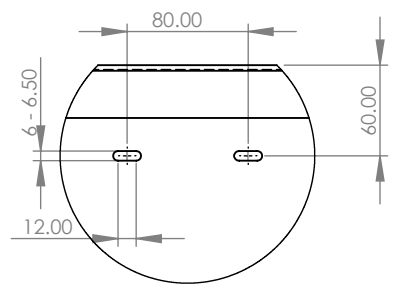

DETAIL D  
SCALE 1 : 5

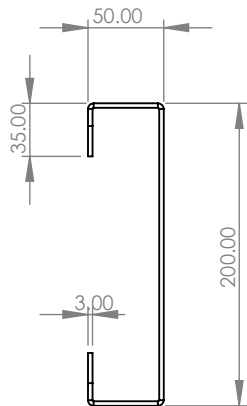

SCALE 1:5

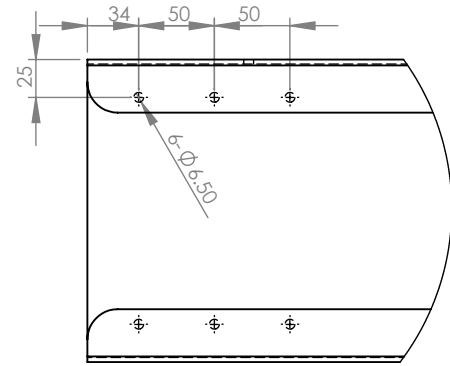

DETAIL E  
SCALE 1 : 5

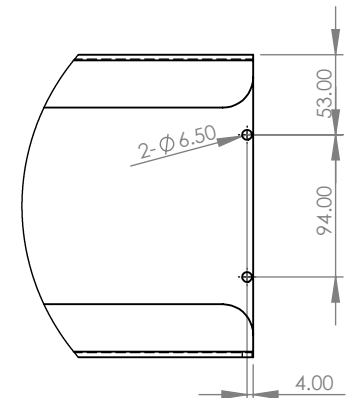

DETAIL F  
SCALE 1 : 5

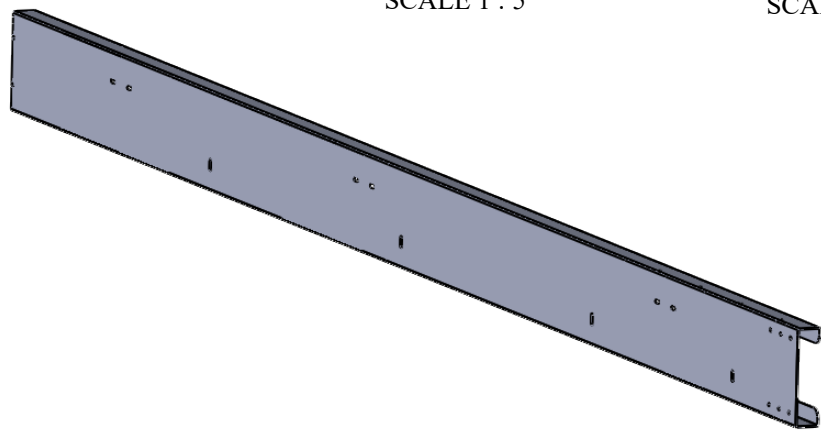

Yêu cầu:

				Project																	
				Drawing No.																	
<b>VAI BĂNG TẢI 1-2</b>				Material																	
				SS400		Qty															
<table border="1"> <thead> <tr> <th>A4</th> <th>NAME</th> <th>SIGNATURE</th> <th>DATE</th> </tr> </thead> <tbody> <tr> <td>DRAWN</td> <td>K.C.Khanh</td> <td></td> <td></td> </tr> <tr> <td>CHEK'D</td> <td>P.V.Thành</td> <td></td> <td></td> </tr> <tr> <td>APPV'D</td> <td></td> <td></td> <td></td> </tr> </tbody> </table>				A4	NAME	SIGNATURE	DATE	DRAWN	K.C.Khanh			CHEK'D	P.V.Thành			APPV'D				Scale	
A4	NAME	SIGNATURE	DATE																		
DRAWN	K.C.Khanh																				
CHEK'D	P.V.Thành																				
APPV'D																					
				1:15	1																



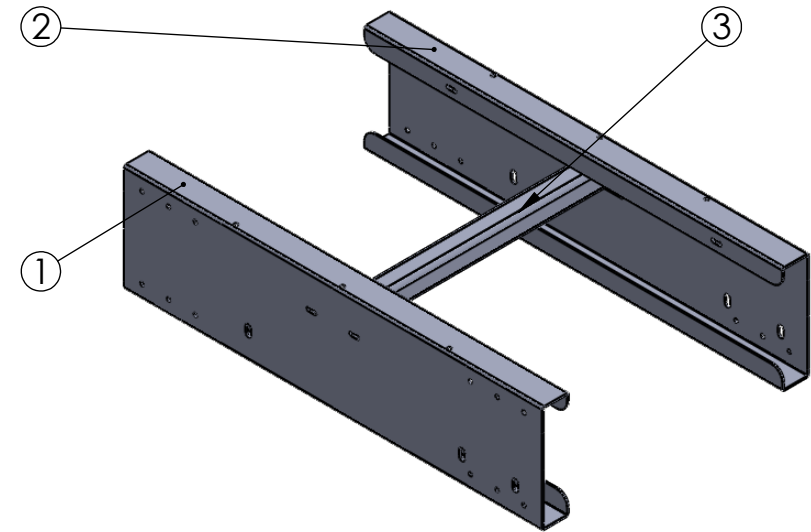
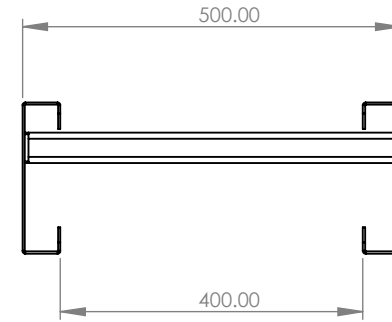
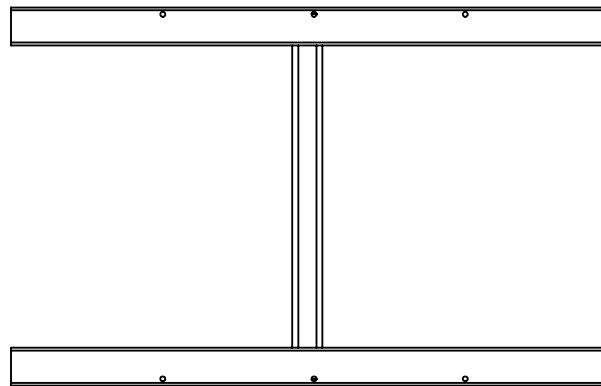
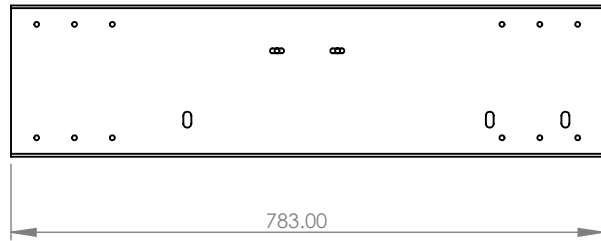

2	CUM THANH GIANG BANG TAI	AKIA	2		
2	VAI BANG TAI 2-2	AKIA	1		
1	VAI BANG TAI 2-1	AKIA	1		
<i>No</i>	<i>Part name</i>	<i>Maker</i>	<i>Qty</i>	<i>Part code</i>	<i>Specification</i>

**PART LIST**

				<i>Project</i>	
				<i>Drawing No.</i>	
<b>KHUNG NGANG 2 (W500-L5230-H1166)</b>				<i>Part name</i>	
				<i>Material</i>	
<i>A4</i>	<i>NAME</i>	<i>SIGNATURE</i>	<i>DATE</i>	<i>Scale</i>	
DRAWN	K.C.Khanh			SUS304	
CHEK'D	P.V.Thành			1:10	
APPV'D				1	

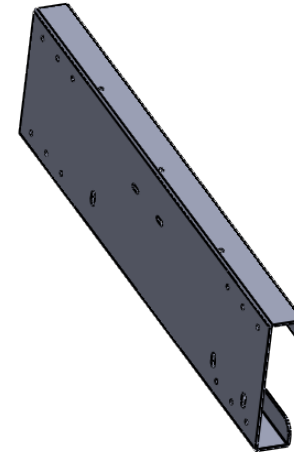
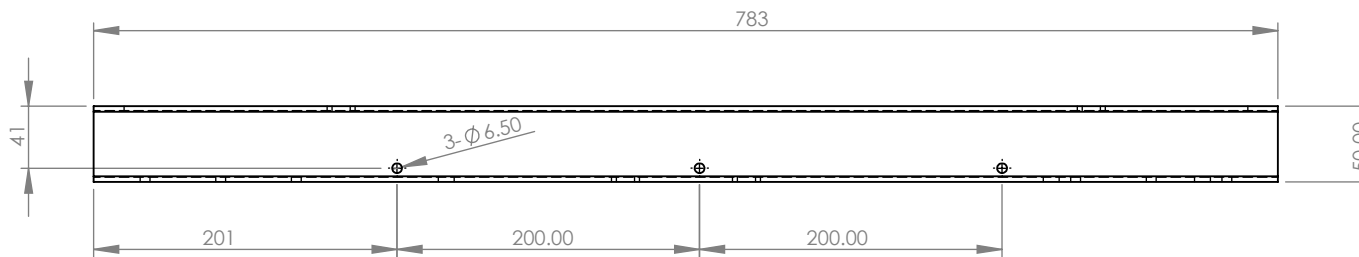
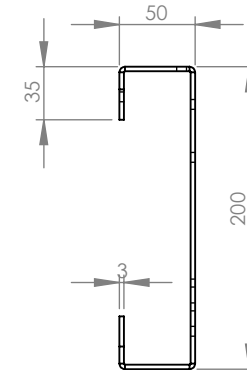
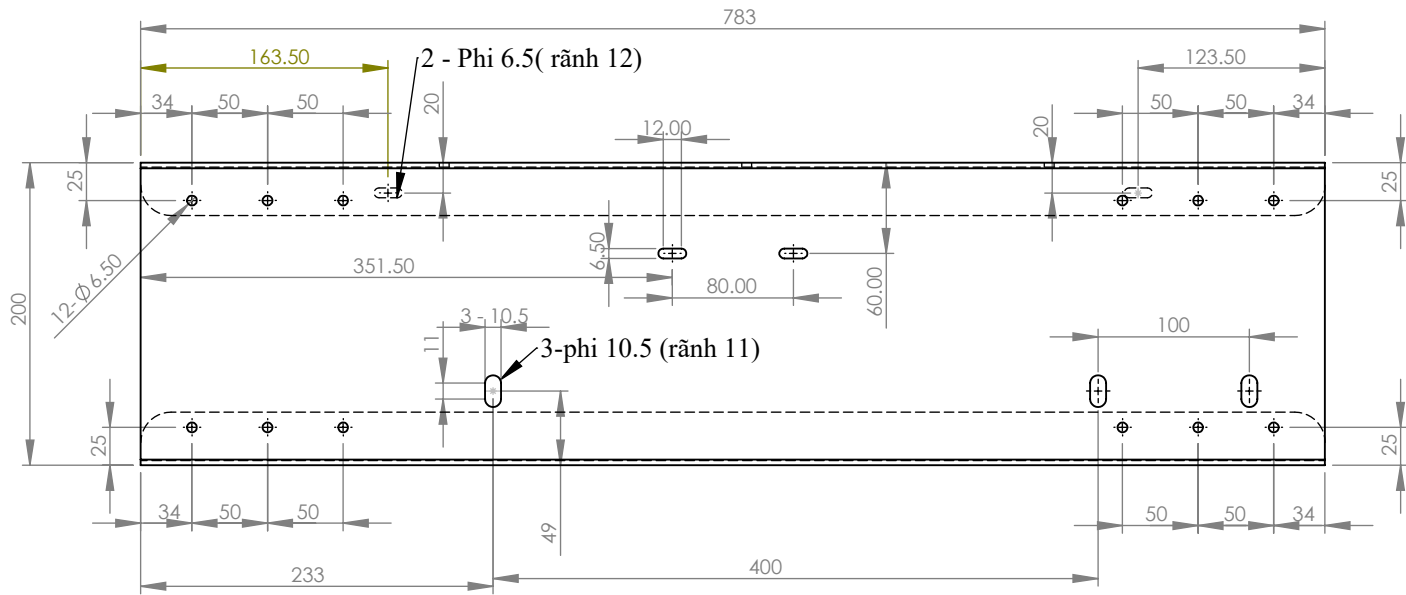

Yêu cầu:

				Project	
				Drawing No.	
<b>VAI BĂNG TẢI 2 -1</b>				Material	
				SS400	Qty
APPV'D				Scale	1

A4	NAME	SIGNATURE	DATE
DRAWN	K.C.Khanh		
CHEK'D	P.V.Thành		
APPV'D			

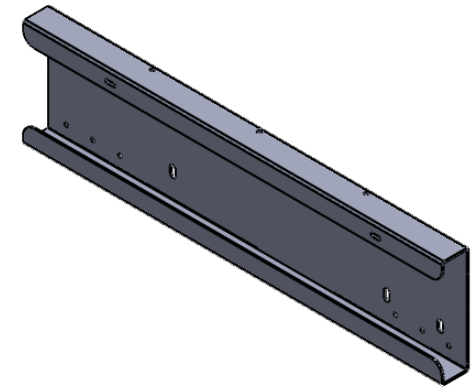
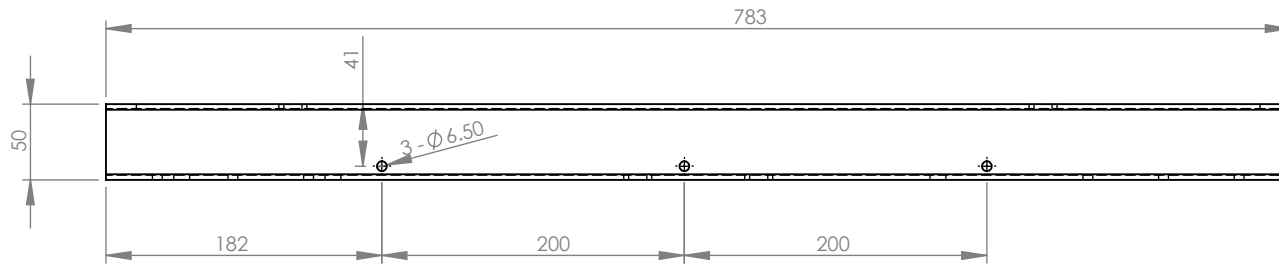
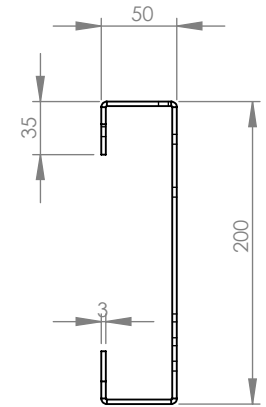
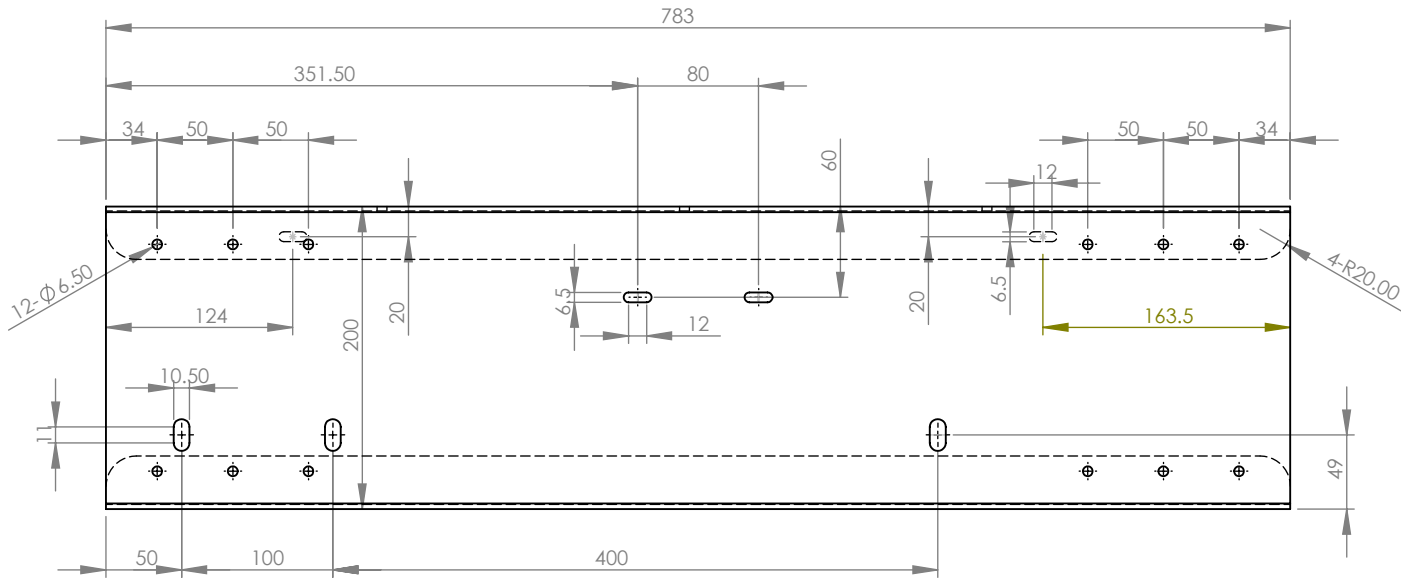

Yêu cầu:

				Project	
				Drawing No.	
<b>VAI BĂNG TÀI 2-2</b>				Part name	
				Material	
A4	NAME	SIGNATURE	DATE	SS400	Qty
DRAWN	K.C.Khanh			Scale	1
CHEK'D	P.V.Thành			1:5	
APPV'D					

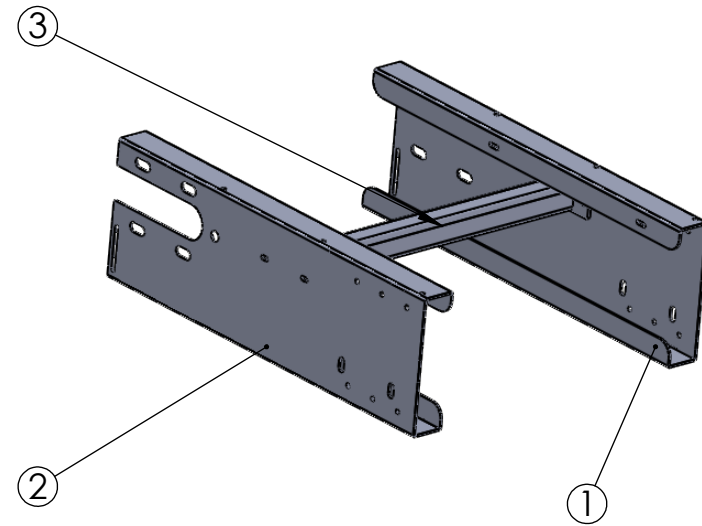
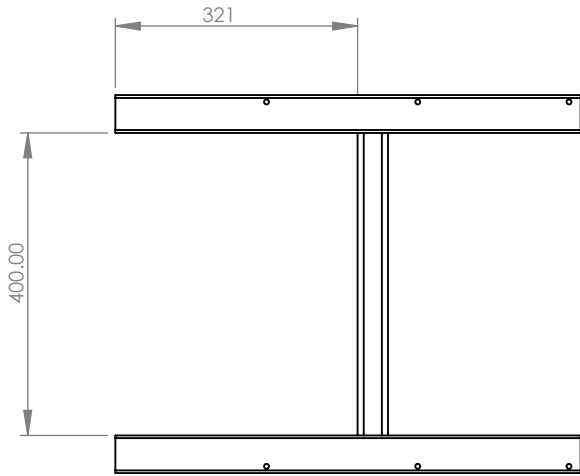
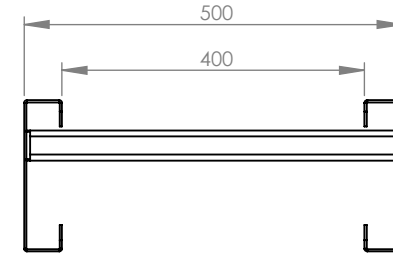
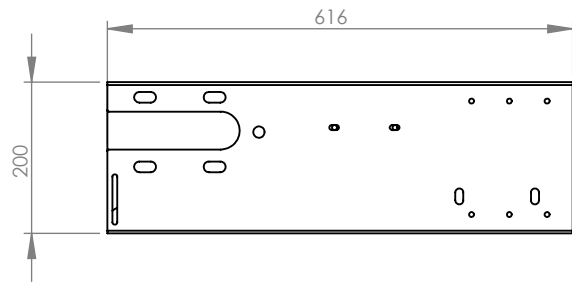

2	CUM THANH GIANG BANG TAI	AKIA	2	SS400		
2	VAI BANG TAI 2	AKIA	1	SS400		
1	VAI BANG TAI 1	AKIA	1	SS400		
<i>No</i>	<i>Part name</i>	<i>Maker</i>	<i>Qty</i>	<i>Material</i>	<i>Part code</i>	<i>Specification</i>

### PART LIST

 <b>AKIA VIET NAM</b>				<i>Project</i>	
				<i>Drawing No.</i>	
<b>KHUNG NGANG 3 (BT W500-L5230-H1166)</b>				<i>Part name</i>	
				<i>Material</i>	
<i>A4</i>	<i>NAME</i>	<i>SIGNATURE</i>	<i>DATE</i>	SS400	<i>Qty</i>
DRAWN	K.C.Khanh			Scale	1
CHEK'D	P.V.Thành			1:10	
APPV'D					

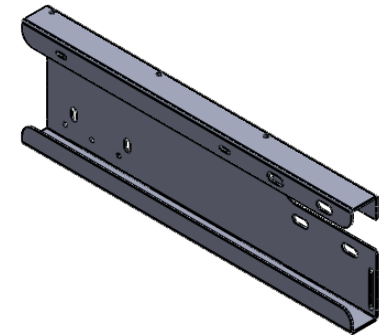
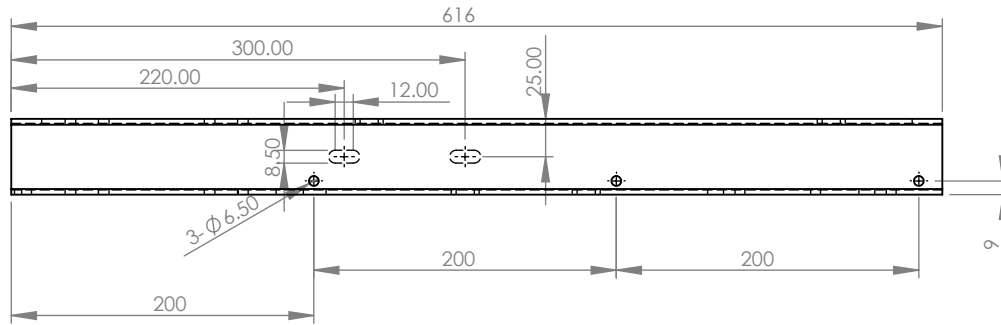
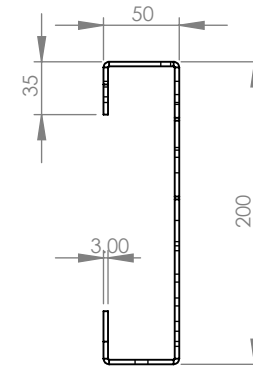
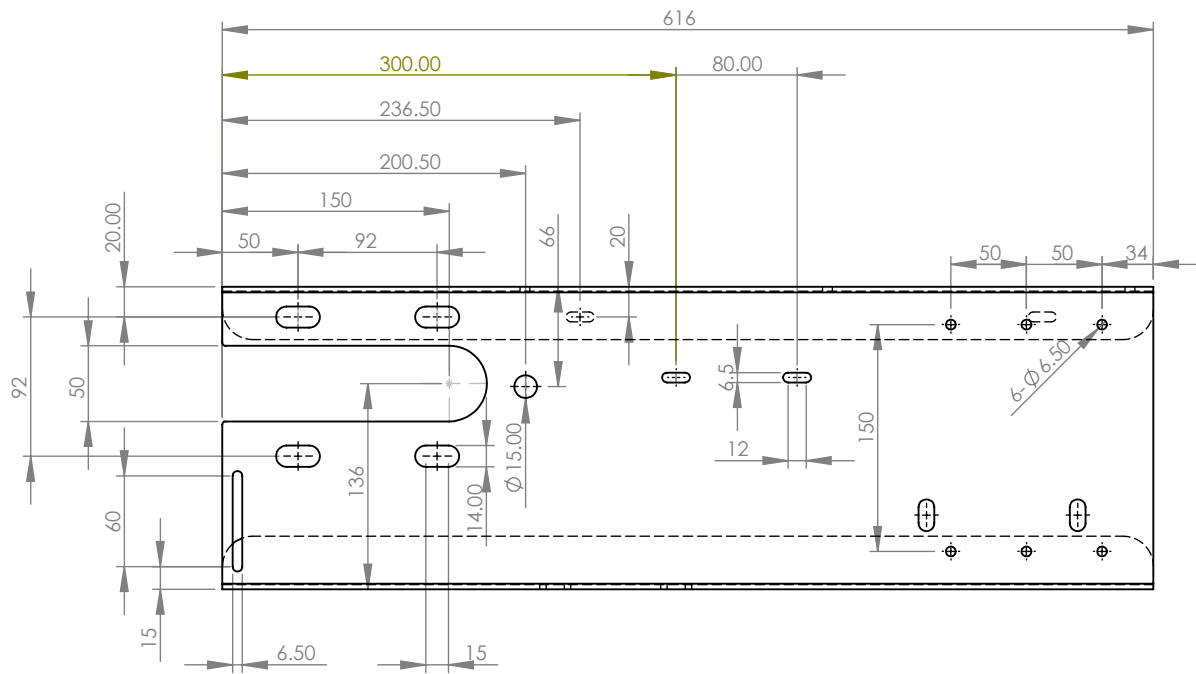

Yêu cầu:

 <b>AKIA VIET NAM</b>				Project																			
				Drawing No.																			
<table border="1"> <tr> <td colspan="2">Part name</td> <td colspan="2" rowspan="2" style="text-align: center;"><b>VAI BĂNG TẢI 3-1</b></td> </tr> <tr> <td colspan="2">Material</td> </tr> <tr> <td colspan="2"></td> <td style="text-align: center;">SS400</td> <td style="text-align: center;">Qty</td> </tr> <tr> <td colspan="2"></td> <td style="text-align: center;">Scale</td> <td style="text-align: center;">1</td> </tr> <tr> <td colspan="2"></td> <td style="text-align: center;">1:2</td> <td></td> </tr> </table>				Part name		<b>VAI BĂNG TẢI 3-1</b>		Material				SS400	Qty			Scale	1			1:2			
				Part name				<b>VAI BĂNG TẢI 3-1</b>															
Material																							
		SS400	Qty																				
		Scale	1																				
		1:2																					
<b>A4</b>	<b>NAME</b>	<b>SIGNATURE</b>	<b>DATE</b>																				
DRAWN	K.C.Khanh																						
CHEK'D	P.V.Thành																						
APPV'D																							

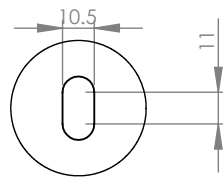
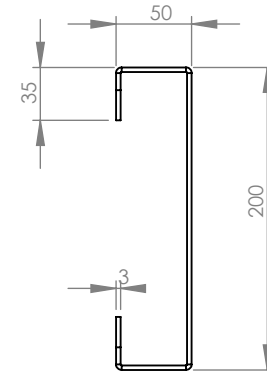
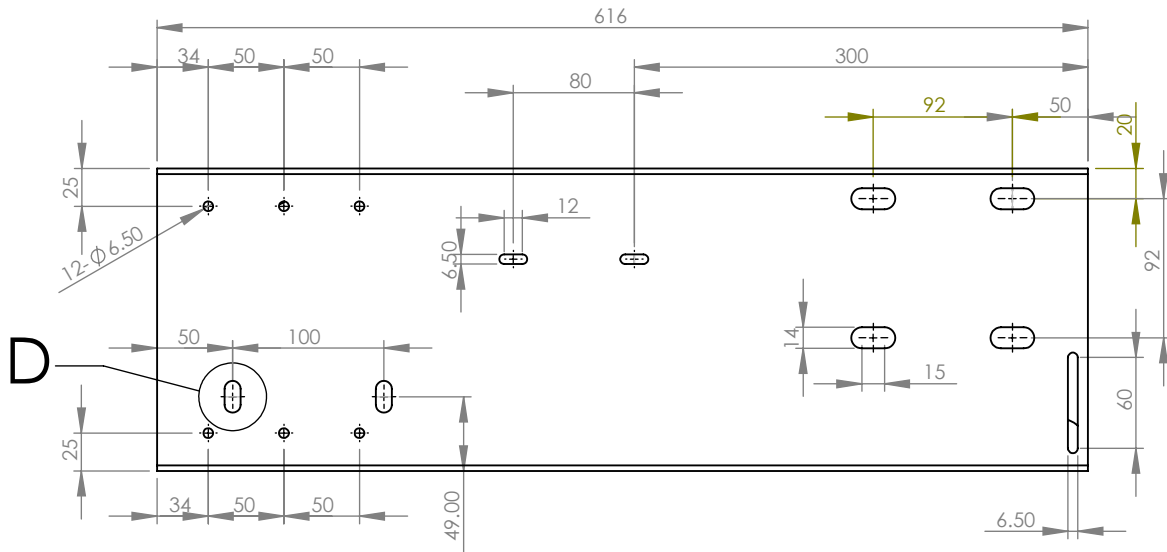

DETAIL D  
SCALE 2 : 5

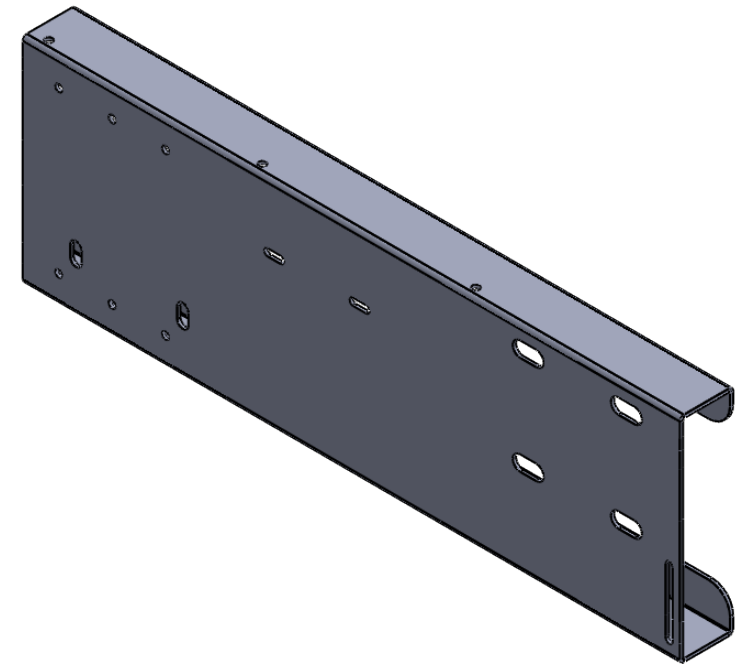
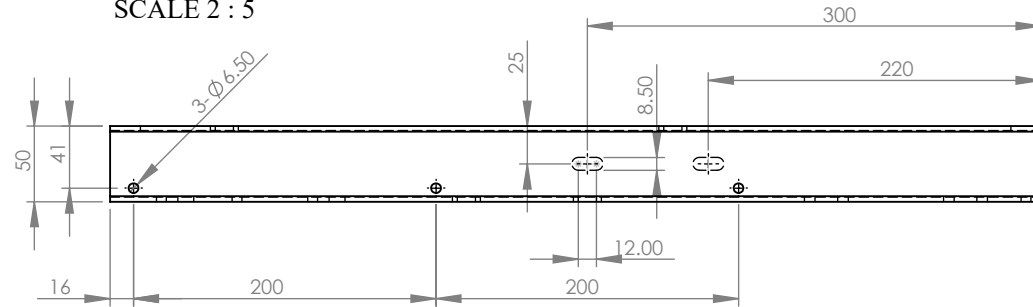

Yêu cầu:

				Project	
				Drawing No.	
<b>AKIA VIET NAM</b>				Part name	
				VAI BĂNG TẢI 3-2	
DRAWN K.C.Khanh CHECK'D P.V.Thành APPV'D				Material	
				SS400	
A4 NAME SIGNATURE DATE				Q.ty	
				Scale 1:5	
1<L≤6±0.05, (±0.05); 6<L≤30±0.1, (±0.05); 30<L≤120±0.15, (±0.1); 120<L≤400±0.2, (±0.1); 400<L≤1000±0.3				1	

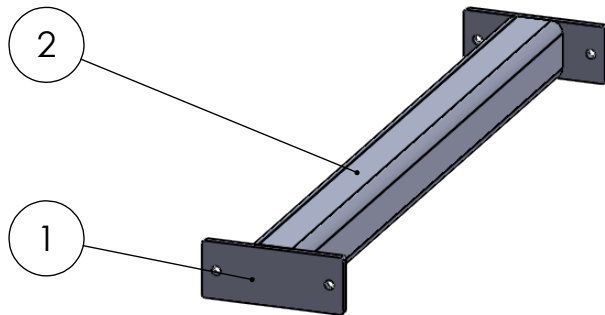
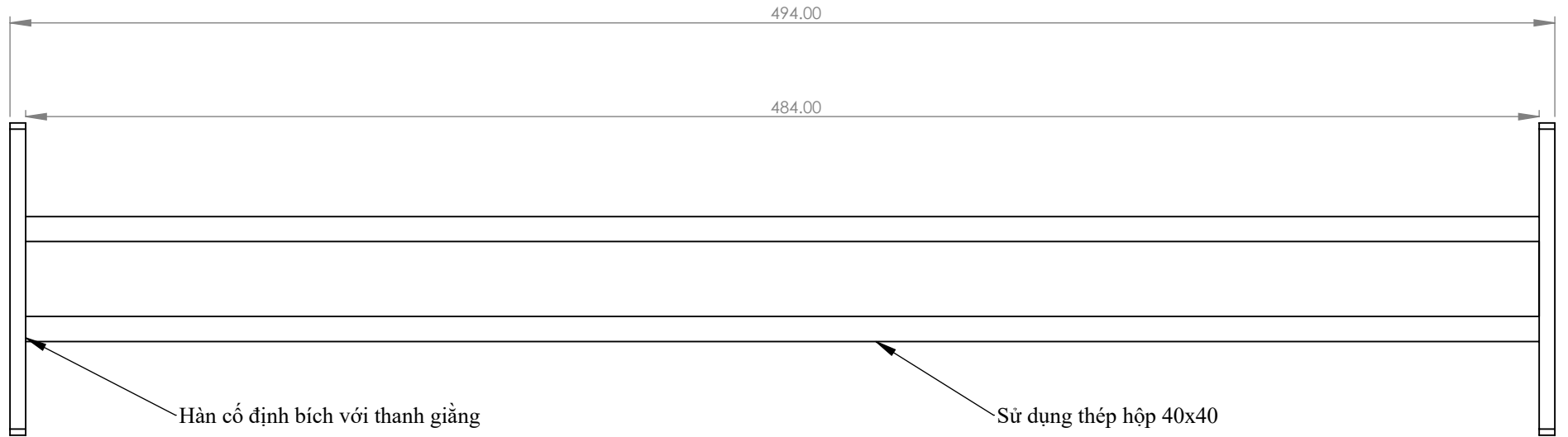

2	THÉP HỘP 40X40	AKIA	1	SS400		
1	BÍCH THANH GIẰNG BĂNG TÀI	AKIA	2	SS400		
No	Part name	Maker	Qty	Material	Part code	Specification

**PART LIST**

				Project																																		
				Drawing No.																																		
<b>CỤM THANH GIẰNG BĂNG TÀI</b>				Part name																																		
				Material																																		
<table border="1"> <tr> <td><i>A4</i></td> <td><i>NAME</i></td> <td><i>SIGNATURE</i></td> <td><i>DATE</i></td> <td colspan="2"></td> </tr> <tr> <td>DRAWN</td> <td>K.C.Khanh</td> <td></td> <td></td> <td colspan="2"></td> </tr> <tr> <td>CHEK'D</td> <td>P.V.Thành</td> <td></td> <td></td> <td colspan="2"></td> </tr> <tr> <td>APPV'D</td> <td></td> <td></td> <td></td> <td colspan="2"></td> </tr> </table>				<i>A4</i>	<i>NAME</i>	<i>SIGNATURE</i>	<i>DATE</i>			DRAWN	K.C.Khanh					CHEK'D	P.V.Thành					APPV'D						<table border="1"> <tr> <td colspan="2">SS400</td> <td>Qty</td> </tr> <tr> <td colspan="2">Scale</td> <td></td> </tr> <tr> <td colspan="2">1:2</td> <td>5</td> </tr> </table>		SS400		Qty	Scale			1:2		5
<i>A4</i>	<i>NAME</i>	<i>SIGNATURE</i>	<i>DATE</i>																																			
DRAWN	K.C.Khanh																																					
CHEK'D	P.V.Thành																																					
APPV'D																																						
SS400		Qty																																				
Scale																																						
1:2		5																																				

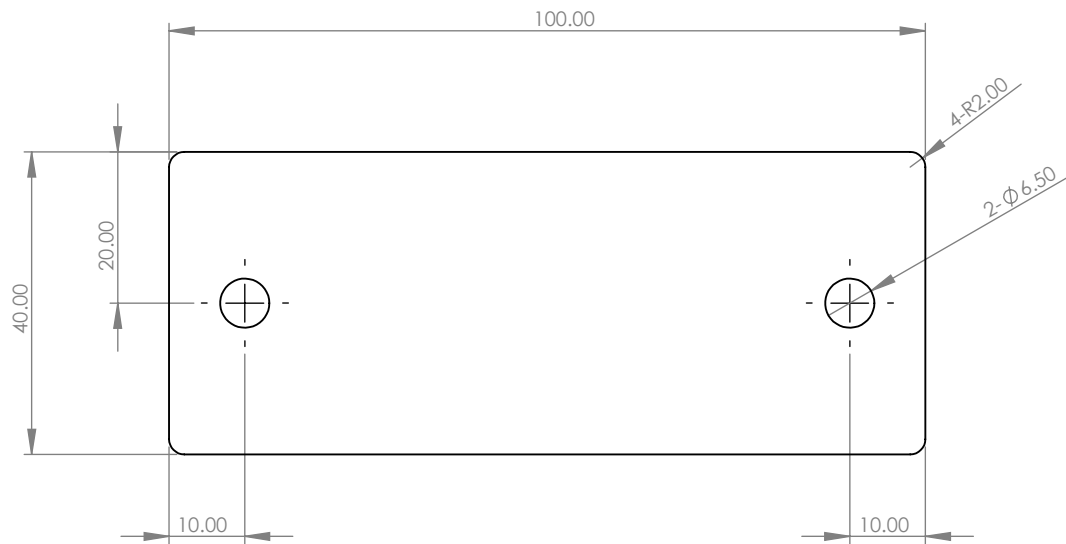

Yêu cầu:

 <b>AKIA VIET NAM</b>				<u>Project</u>	
				<u>Drawing No.</u>	
				<u>Part name</u>	
				<b>BÍCH THANH GIẢNG KHUNG</b>	
<u>A4</u>	<u>NAME</u>	<u>SIGNATURE</u>	<u>DATE</u>	<u>Material</u>	
DRAWN	K.C.Khanh			SS400	
CHECK'D	P.V.Thành			Q.ty	
APPV'D				Scale 1:1	
				10	



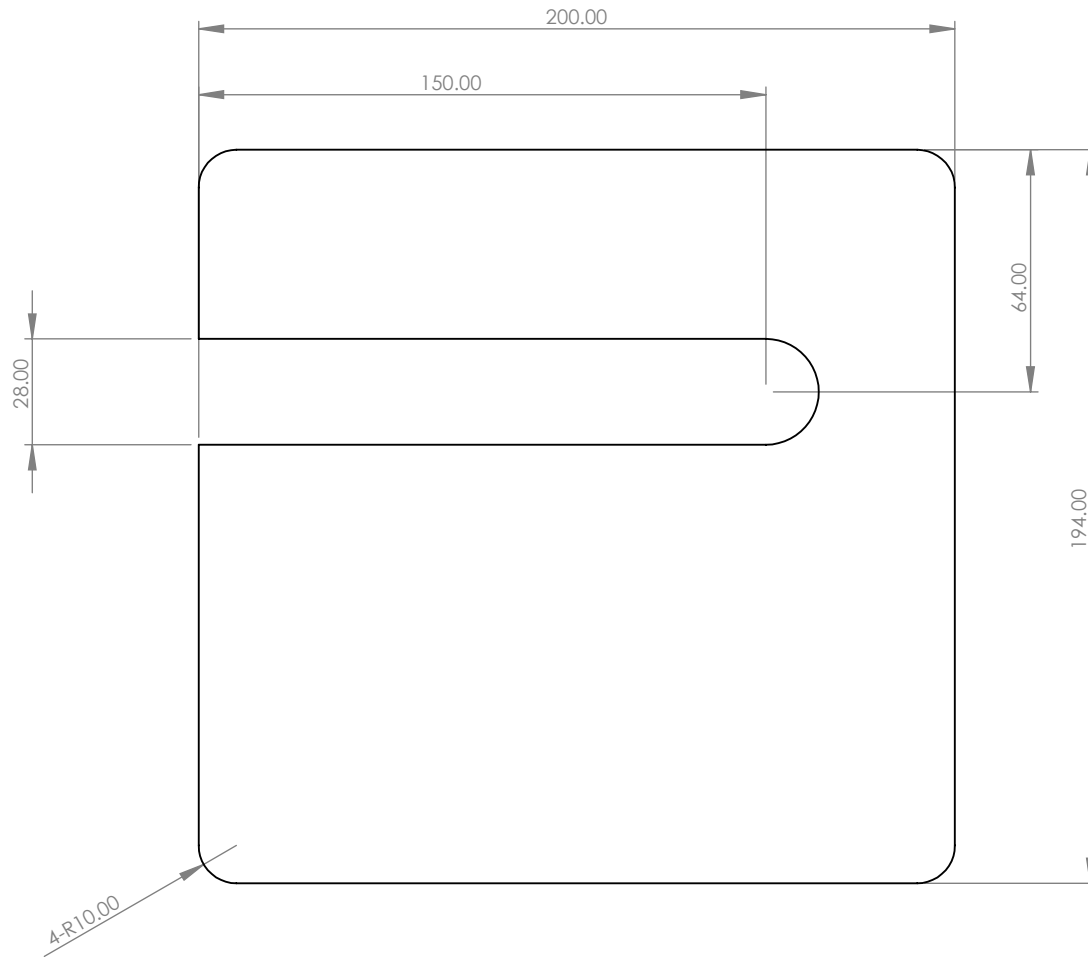

Yêu cầu:

 <b>AKIA VIET NAM</b>				<i>Project.</i>							
				<i>Drawing No.</i>							
<table border="1"> <tr> <td colspan="2"><i>Part name.</i></td> </tr> <tr> <td colspan="2" style="text-align: center;"><b>BÍCH ĐỖ CON LẮN BỊ ĐỘNG</b></td> </tr> </table>				<i>Part name.</i>		<b>BÍCH ĐỖ CON LẮN BỊ ĐỘNG</b>		<i>Material.</i>			
				<i>Part name.</i>							
<b>BÍCH ĐỖ CON LẮN BỊ ĐỘNG</b>											
<table border="1"> <tr> <td colspan="2" style="text-align: center;"><b>SS400</b></td> <td style="text-align: center;"><i>Q.ty</i></td> </tr> <tr> <td colspan="2" style="text-align: center;"><i>Scale</i> 1:2</td> <td style="text-align: center;">2</td> </tr> </table>				<b>SS400</b>		<i>Q.ty</i>	<i>Scale</i> 1:2		2		
				<b>SS400</b>		<i>Q.ty</i>					
<i>Scale</i> 1:2		2									
<i>A4</i>	<i>NAME</i>	<i>SIGNATURE</i>	<i>DATE</i>								
<i>DRAWN</i>	K.C.Khanh										
<i>CHEK'D</i>	P.V.Thành										
<i>APPV'D</i>											

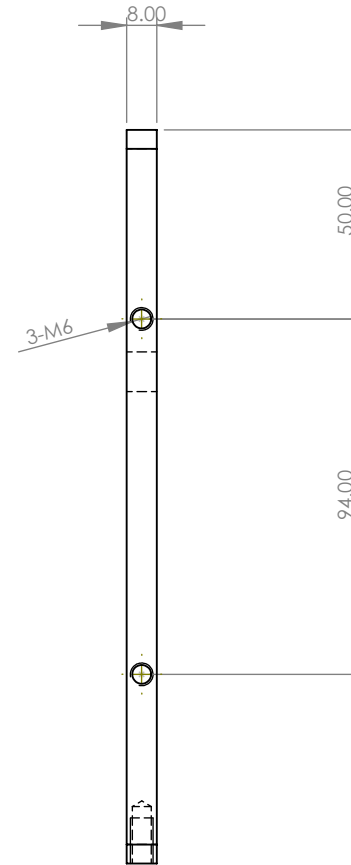
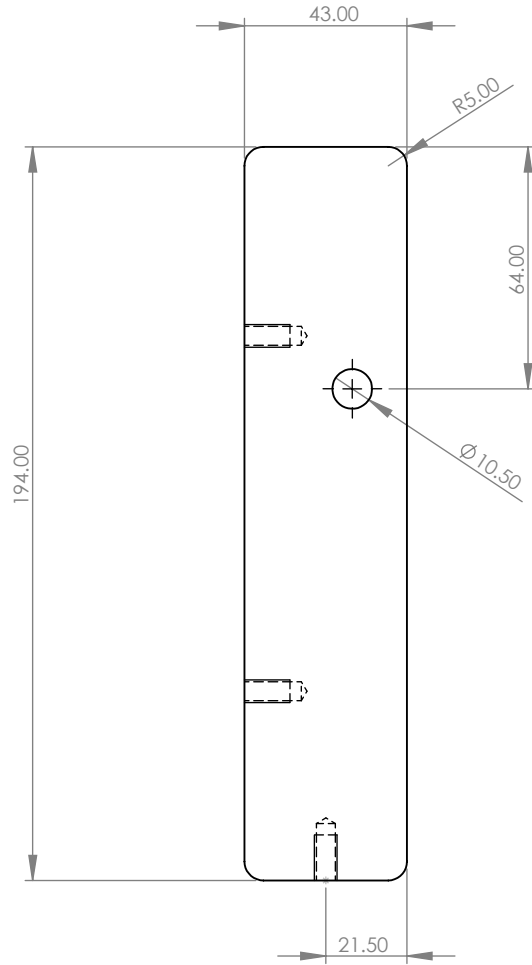

Yêu cầu:

 <b>AKIA VIET NAM</b>				<i>Project</i>	
				<i>Drawing No.</i>	
				<i>Part name</i>	
				BÍCH TĂNG CHỈNH	
<i>A4</i>	<i>NAME</i>	<i>SIGNATURE</i>	<i>DATE</i>	<i>Material</i>	
DRAWN	K.C.Khanh			SS400	
CHEK'D	P.V.Thành			<i>Q.ty</i>	
APPV'D				Scale	2
				1:2	

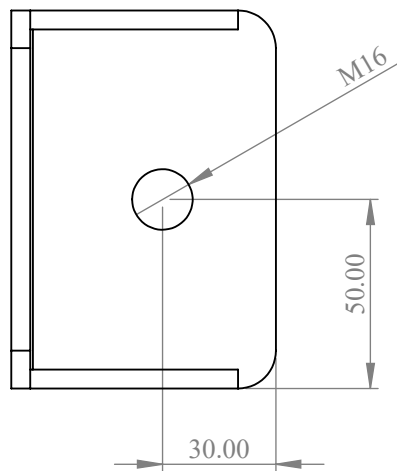
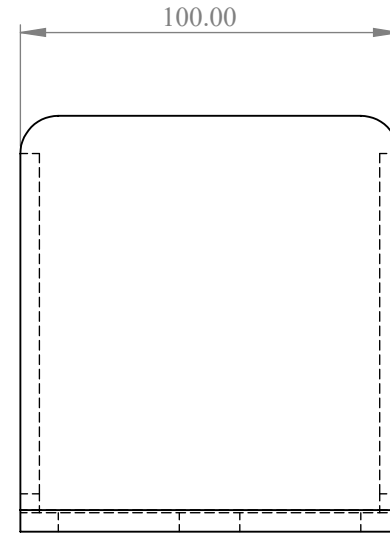
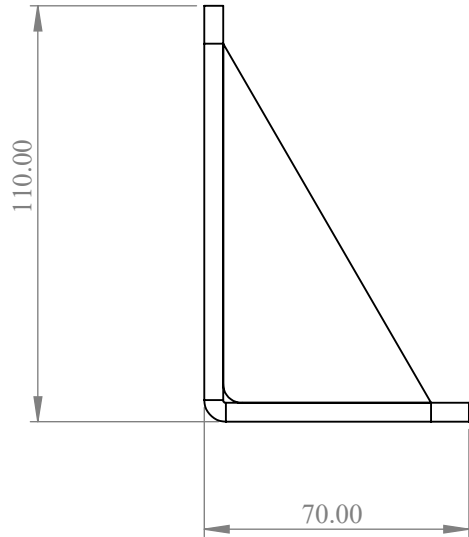

Hàn cố định gân tăng cứng

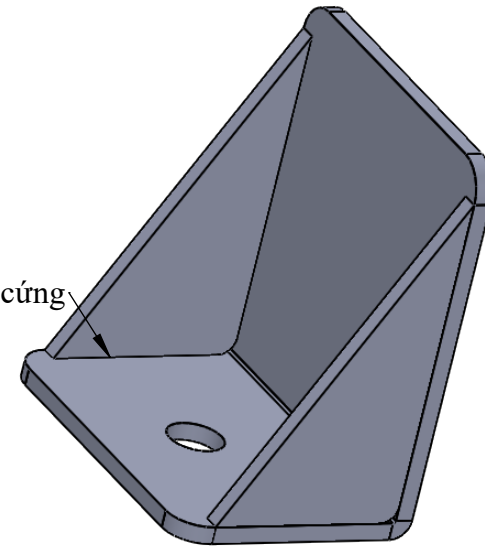

Yêu cầu:

				Project																		
				Drawing No.																		
<b>BÍCH CHÂN TĂNG CHÌNH</b>				Material																		
				SS400		Qty																
<table border="1"> <thead> <tr> <th>A4</th> <th>NAME</th> <th>SIGNATURE</th> <th>DATE</th> </tr> </thead> <tbody> <tr> <td>DRAWN</td> <td>K.C.Khanh</td> <td></td> <td></td> </tr> <tr> <td>CHEK'D</td> <td>P.V.Thành</td> <td></td> <td></td> </tr> <tr> <td>APPV'D</td> <td></td> <td></td> <td></td> </tr> </tbody> </table>				A4	NAME	SIGNATURE	DATE	DRAWN	K.C.Khanh			CHEK'D	P.V.Thành			APPV'D				Scale 1:2		8
A4	NAME	SIGNATURE	DATE																			
DRAWN	K.C.Khanh																					
CHEK'D	P.V.Thành																					
APPV'D																						

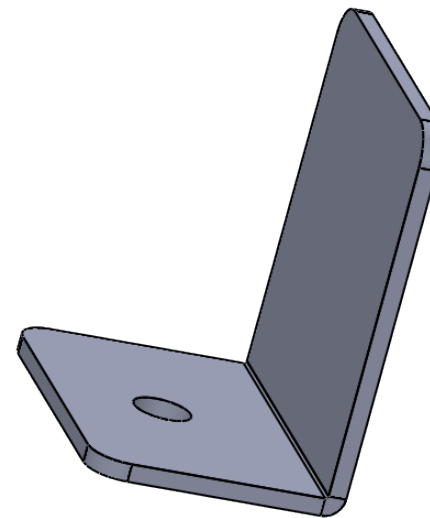
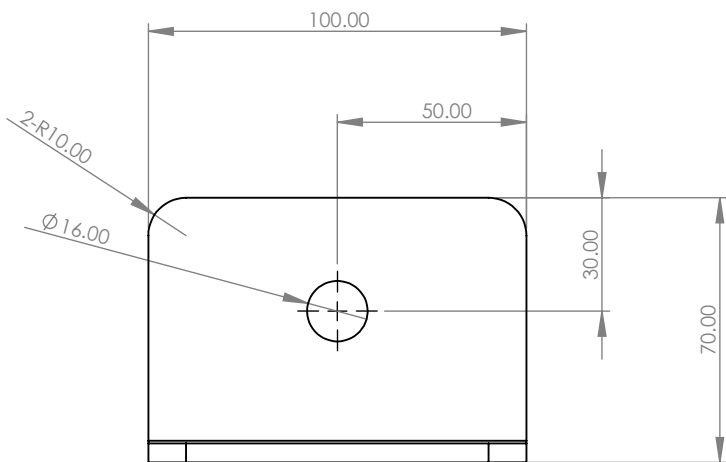
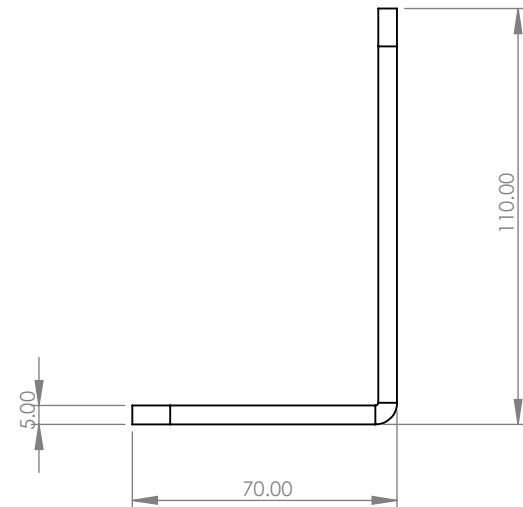
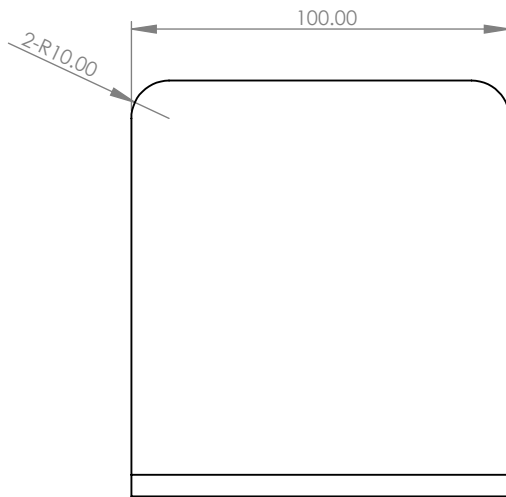

Yêu cầu:

 <b>AKIA VIET NAM</b>				<u>Project</u>																	
				<u>Drawing No.</u>																	
<table border="1"> <tr> <td><u>A4</u></td> <td><u>NAME</u></td> <td><u>SIGNATURE</u></td> <td><u>DATE</u></td> </tr> <tr> <td>DRAWN</td> <td>K.C.Khanh</td> <td></td> <td></td> </tr> <tr> <td>CHEK'D</td> <td>P.V.Thành</td> <td></td> <td></td> </tr> <tr> <td>APPV'D</td> <td></td> <td></td> <td></td> </tr> </table>				<u>A4</u>	<u>NAME</u>	<u>SIGNATURE</u>	<u>DATE</u>	DRAWN	K.C.Khanh			CHEK'D	P.V.Thành			APPV'D				<u>Part name</u>	
				<u>A4</u>	<u>NAME</u>	<u>SIGNATURE</u>	<u>DATE</u>														
DRAWN	K.C.Khanh																				
CHEK'D	P.V.Thành																				
APPV'D																					
				BÍCH NÓI CHÂN TẦNG CHÍNH																	
				<u>Material</u>																	
				SS400	Q.ty																
				Scale	8																
				1:2																	

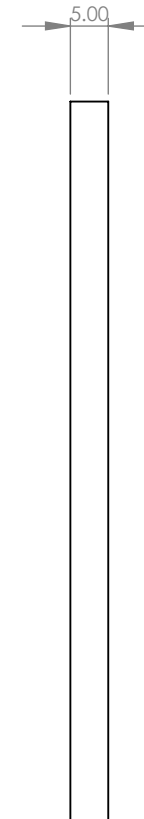
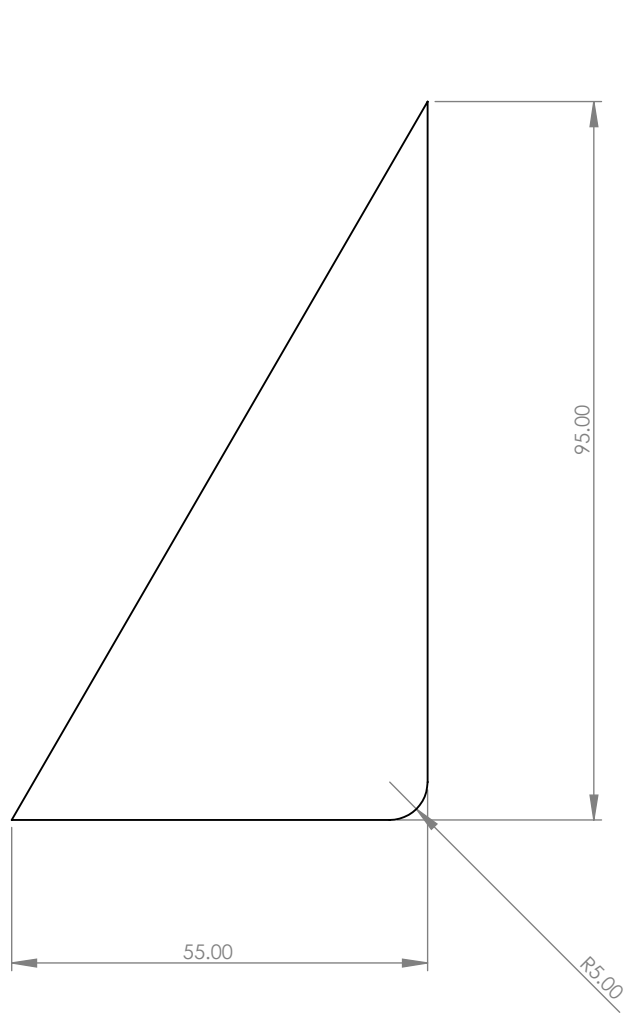

Yêu cầu:

 <b>AKIA VIET NAM</b>				<u>Project</u>	
				<u>Drawing No.</u>	
				<u>Part name</u>	
				<b>GÂN TĂNG CỨNG BÍCH NỐI CHÂN TĂNG CHÍNH</b>	
<u>A4</u>	<u>NAME</u>	<u>SIGNATURE</u>	<u>DATE</u>	<u>Material</u>	<u>Q.ty</u>
DRAWN	K.C.Khanh			SS400	
CHEK'D	P.V.Thành			Scale	16
APPV'D				1:1	

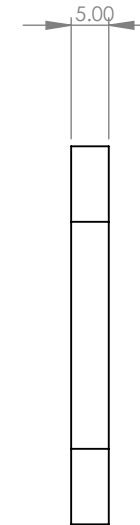
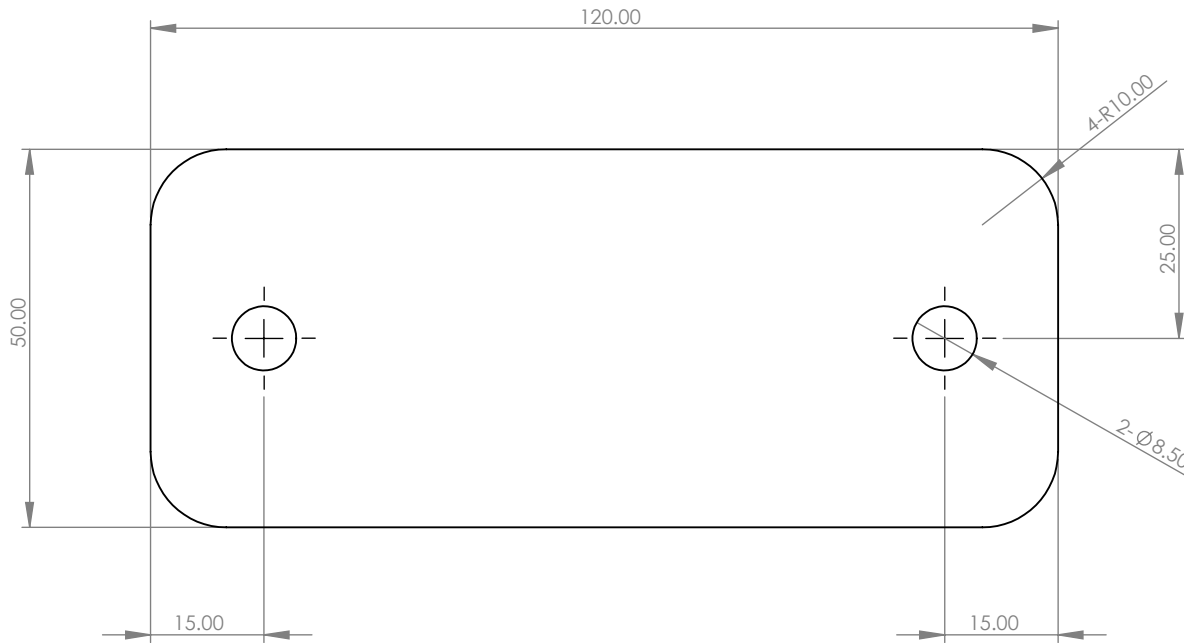

Yêu cầu:

 <b>AKIA VIET NAM</b>				Project													
				Drawing No.													
<table border="1"> <tr> <td colspan="2">Part name</td> <td colspan="2" style="text-align: center;"><b>BÍCH NỐI KHUNG</b></td> </tr> <tr> <td colspan="2">Material</td> <td>SS400</td> <td>Qty</td> </tr> <tr> <td colspan="2">Scale</td> <td>1:1</td> <td>2</td> </tr> </table>				Part name		<b>BÍCH NỐI KHUNG</b>		Material		SS400	Qty	Scale		1:1	2	Material	
				Part name		<b>BÍCH NỐI KHUNG</b>											
Material		SS400	Qty														
Scale		1:1	2														
A4		NAME	SIGNATURE	DATE	Material												
DRAWN		K.C.Khanh			SS400												
CHECK'D		P.V.Thành			Qty												
APPV'D					Scale												
					1:1												
					2												

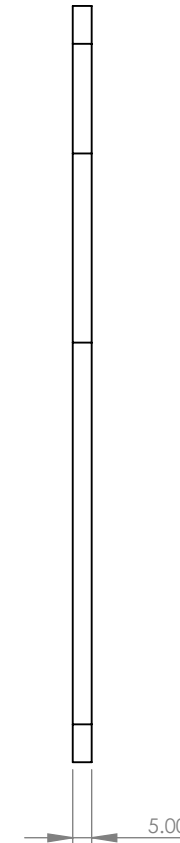
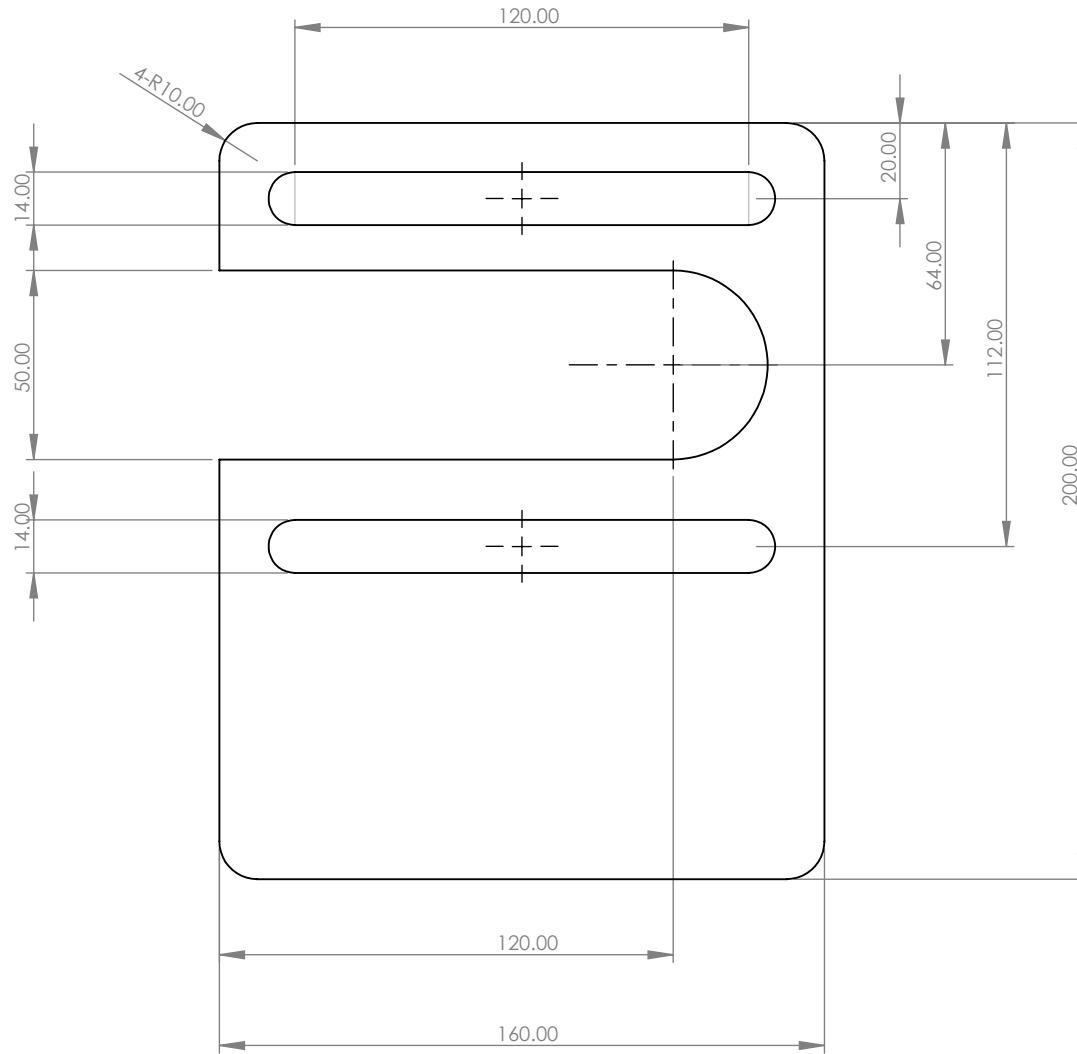

Yêu cầu:

 <b>AKIA VIET NAM</b>				<i>Project.</i>																	
				<i>Drawing No.</i>																	
<table border="1"> <tr> <td><i>A4</i></td> <td><i>NAME</i></td> <td><i>SIGNATURE</i></td> <td><i>DATE</i></td> </tr> <tr> <td>DRAWN</td> <td>K.C.Khanh</td> <td></td> <td></td> </tr> <tr> <td>CHEK'D</td> <td>P.V.Thành</td> <td></td> <td></td> </tr> <tr> <td>APPV'D</td> <td></td> <td></td> <td></td> </tr> </table>				<i>A4</i>	<i>NAME</i>	<i>SIGNATURE</i>	<i>DATE</i>	DRAWN	K.C.Khanh			CHEK'D	P.V.Thành			APPV'D				<i>Part name.</i>	
				<i>A4</i>	<i>NAME</i>	<i>SIGNATURE</i>	<i>DATE</i>														
DRAWN	K.C.Khanh																				
CHEK'D	P.V.Thành																				
APPV'D																					
				<b>BÍCH ÓP TĂNG CỨNG CỤM CHỦ ĐỘNG</b>																	
				<i>Material.</i>																	
				SS400	<i>Q.ty</i>																
				Scale	1																
				1:2																	

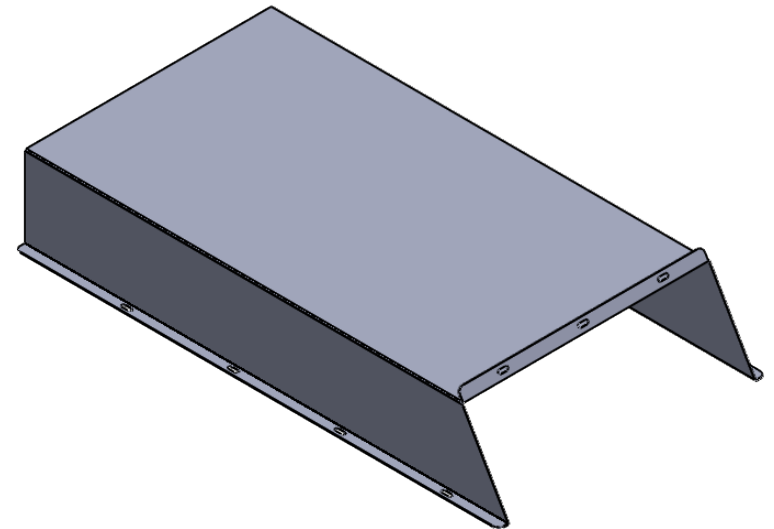
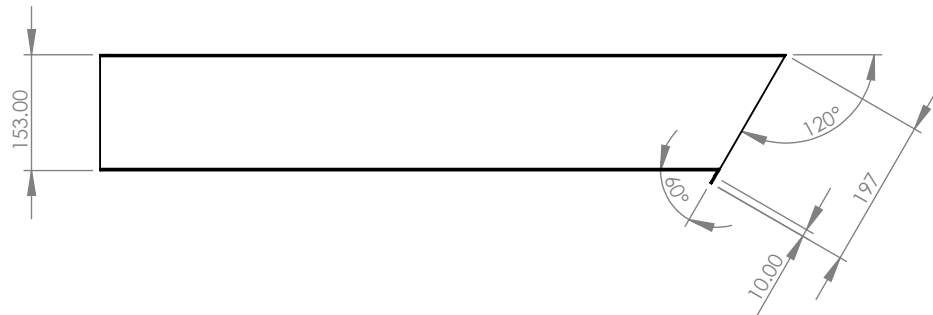
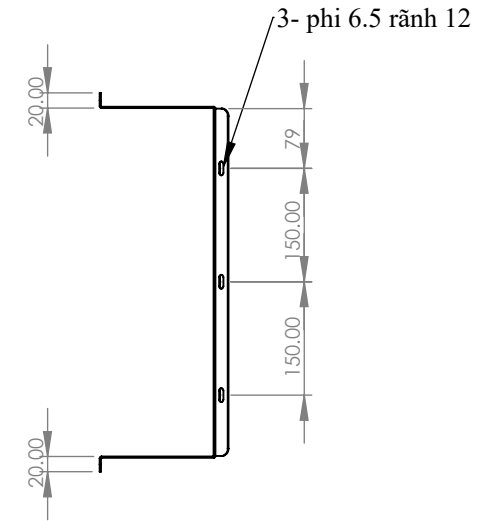
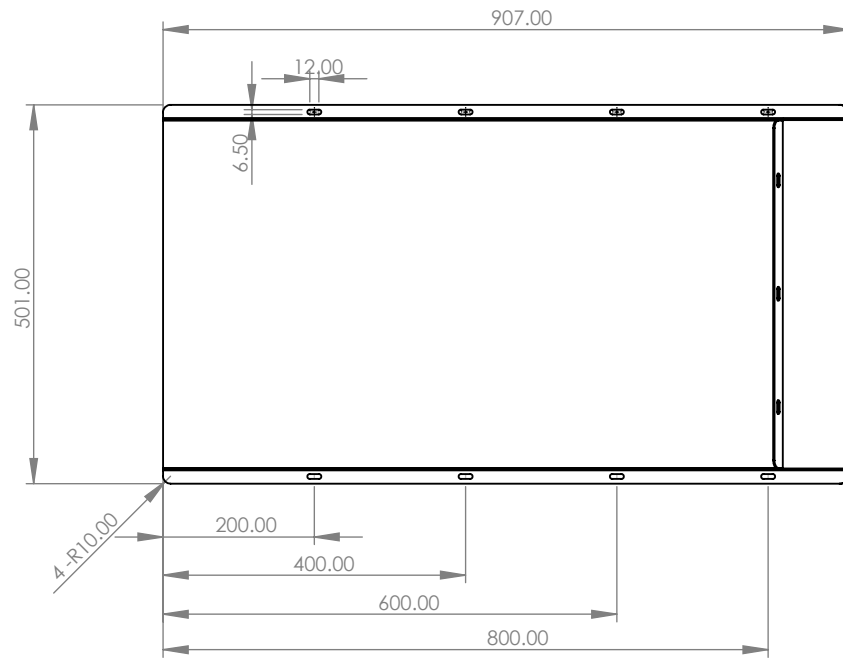

Yêu cầu: - Sử dụng tấm SUS201 dày 1.5mm

				Project	
				Drawing No.	
				Part name	
				COVER BẢNG TÀI 1	
				Material	
				SUS201	
				Scale	
				1:10	
A4	NAME	SIGNATURE	DATE		
DRAWN	K.C.Khanh				
CHEK'D	P.V.Thành				
APPV'D					



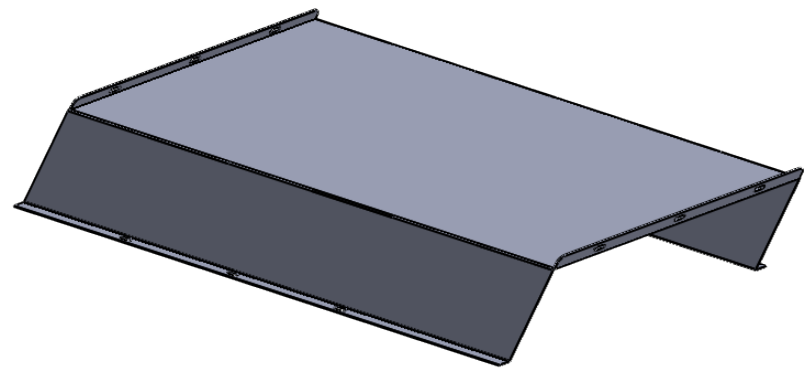
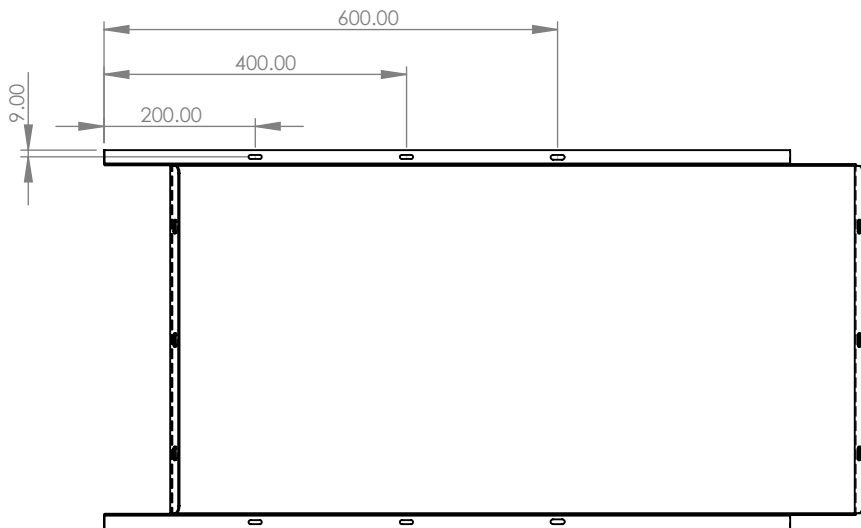
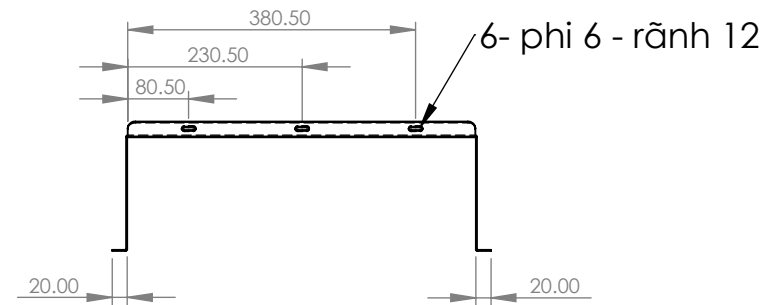
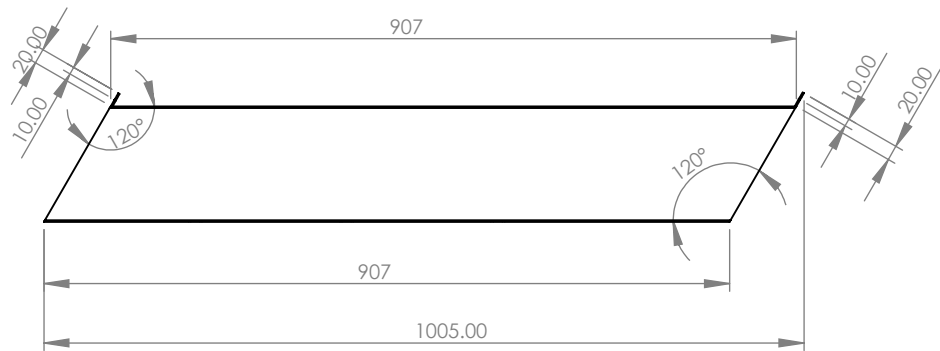

Yêu cầu: dùng tấm inox 201 dày 1.5mm

 <b>AKIA VIET NAM</b>				Project	
				Drawing No.	
				Part name	
				COVER BẢNG TẢI 2	
				Material	
				SUS201	
				Q.ty	
				Scale 1:10	
				1	
APPV'D					

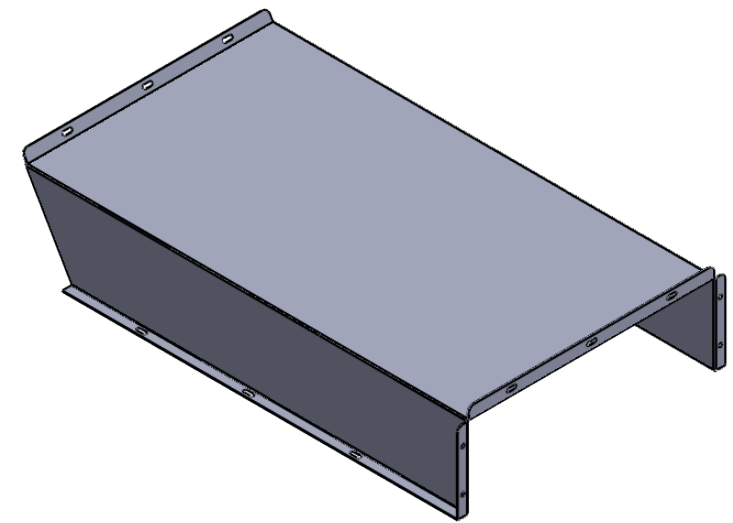
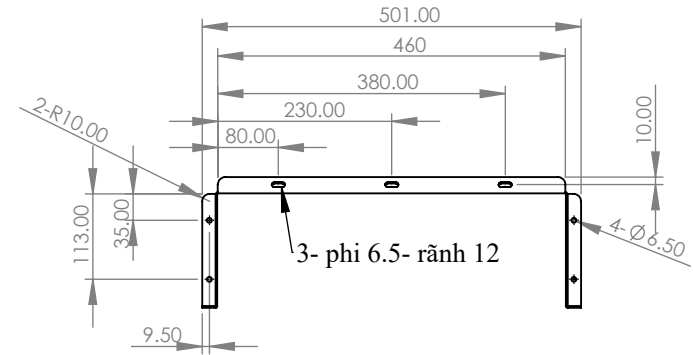
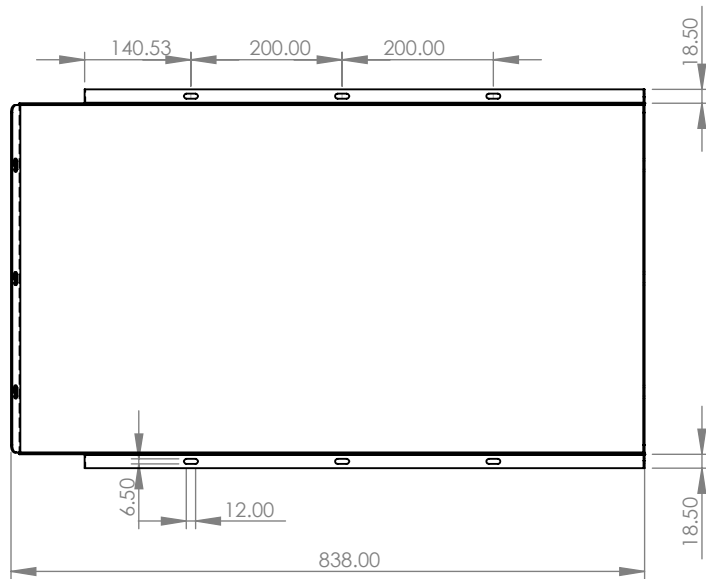
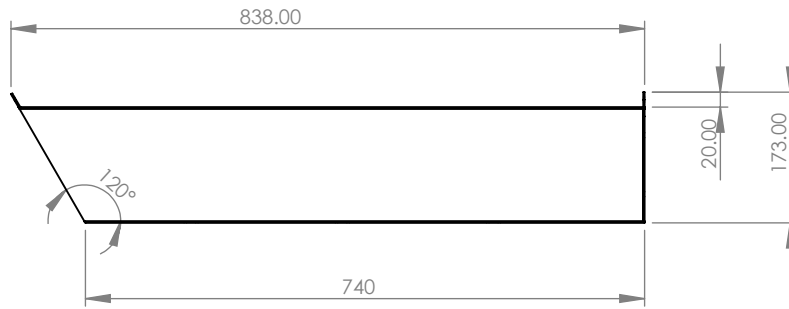

Yêu cầu: Sử dụng tấm inox 201 dày 2mm

				Project	
				Drawing No.	
				Part name	
				COVER BẢNG TẮT 3	
				Material	
				SUS201	
				Scale	
				1:10	
APPV'D					

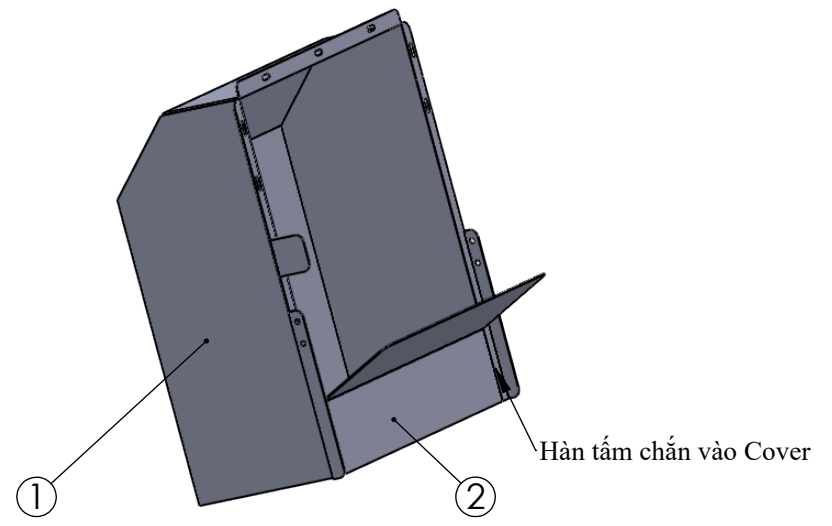
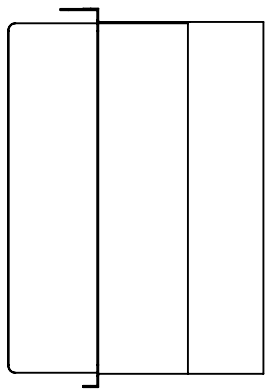
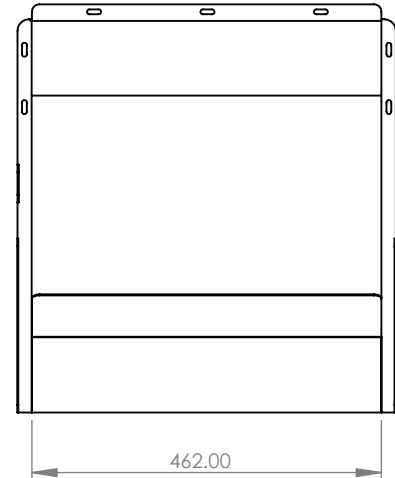
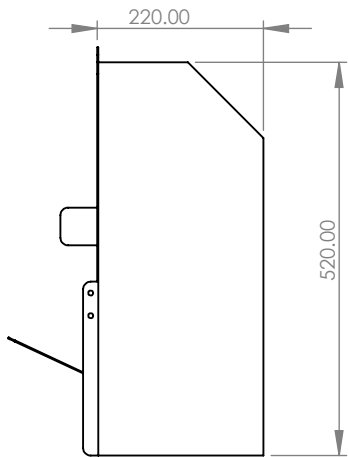

2	TẤM CHÂN COVER	AKIA	1	SUS201		
1	COVER BĂNG TẢI 4	AKIA	1	SUS201		
<i>No</i>	<i>Part name</i>	<i>Maker</i>	<i>Qty</i>	<i>Material</i>	<i>Part code</i>	<i>Specification</i>

**PART LIST**

				<i>Project</i>	
				<i>Drawing No.</i>	
<b>CỤM COVER BĂNG TẢI 4</b>				<i>Part name</i>	
				<i>Material</i>	
<i>A4</i>	<i>NAME</i>	<i>SIGNATURE</i>	<i>DATE</i>	<i>Scale</i>	
DRAWN	K.C.Khanh			1:10	
CHEK'D	P.V.Thành			1	
APPV'D					

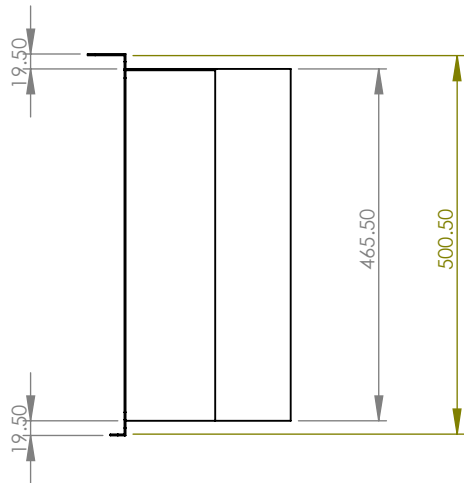
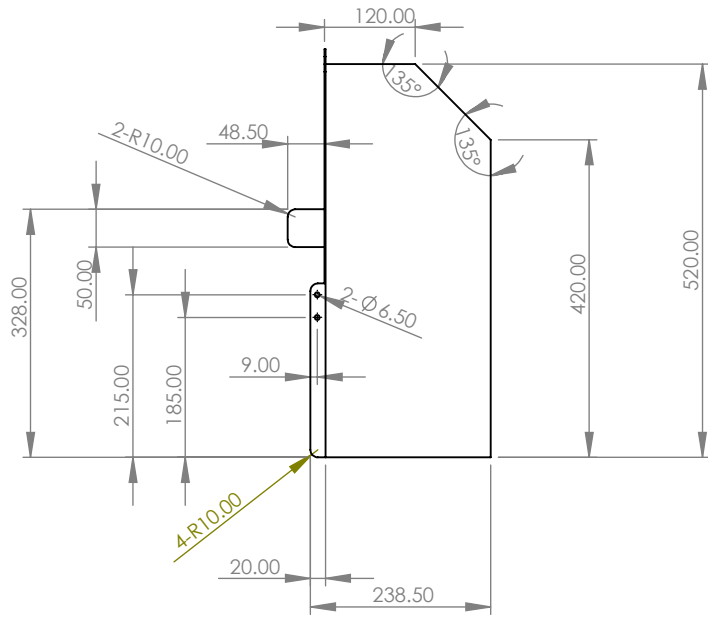

7 - phi 6.5 - rãnh 12

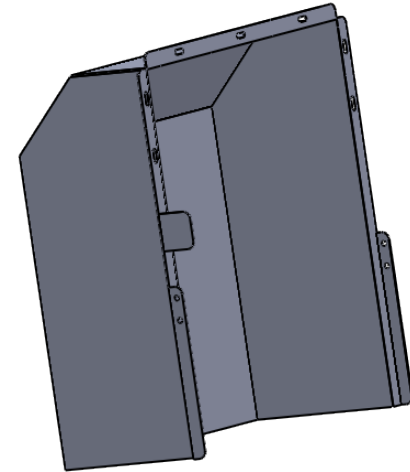
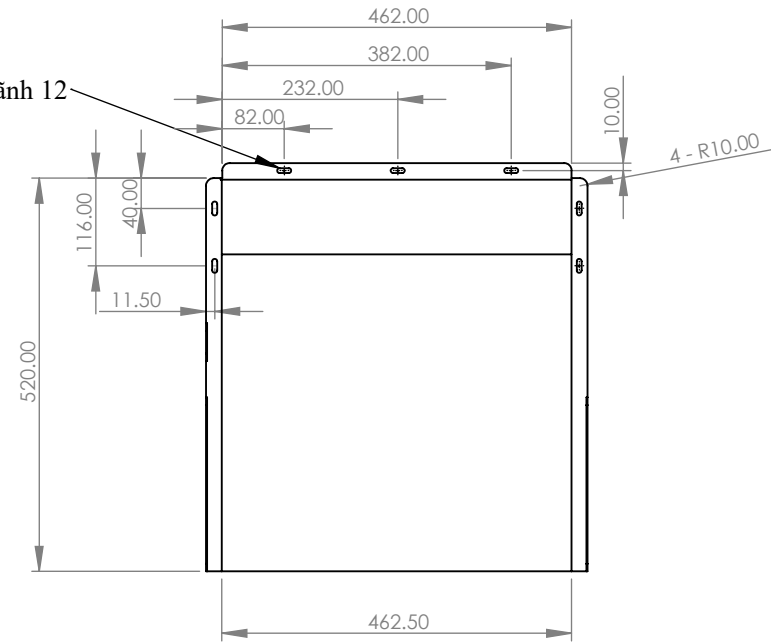

Yêu cầu: Sử dụng tấm inox 201 dày 1.5mm

 <b>AKIA VIET NAM</b>				Project	
				Drawing No.	
				Part name	
				COVER BẢNG TẢI 4	
				Material	
				SUS201	
				Scale	
				1:10	
A4	NAME	SIGNATURE	DATE		
DRAWN	K.C.Khanh				
CHEK'D	P.V.Thành				
APPV'D					

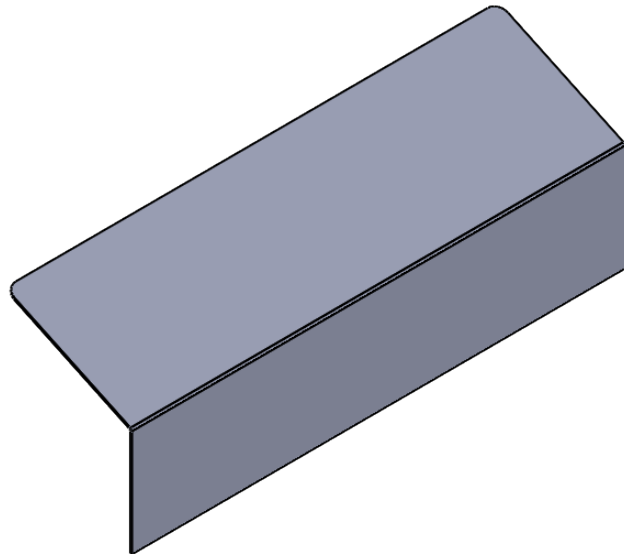
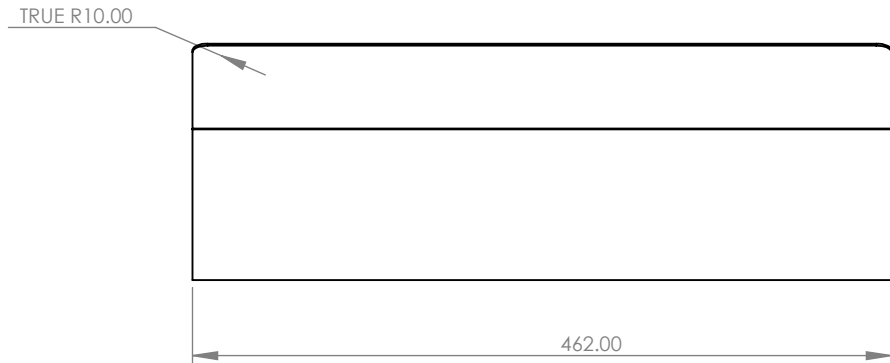
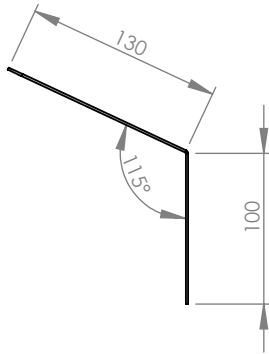

Yêu cầu: Sử dụng tấm inox 201 dày 1.5mm

 <b>AKIA VIET NAM</b>				<i>Project</i>	
				<i>Drawing No.</i>	
				<i>Part name</i>	
				<b>TẤM CHẮN COVER BĂNG TẢI 4</b>	
<i>A4</i>	<i>NAME</i>	<i>SIGNATURE</i>	<i>DATE</i>	<i>Material</i>	<i>Qty</i>
DRAWN	K.C.Khanh			SUS201	
CHEK'D	P.V.Thành			Scale	1
APPV'D				1:10	



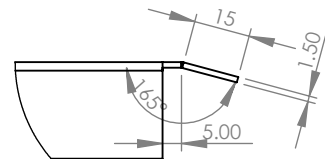
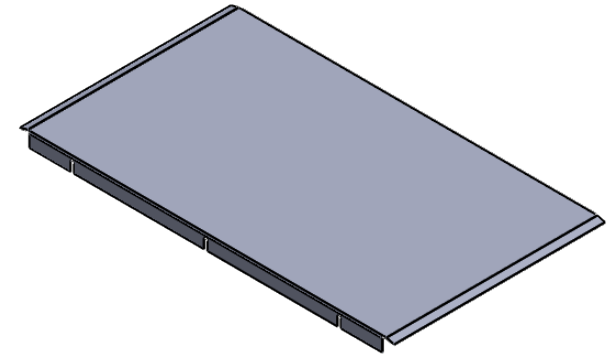
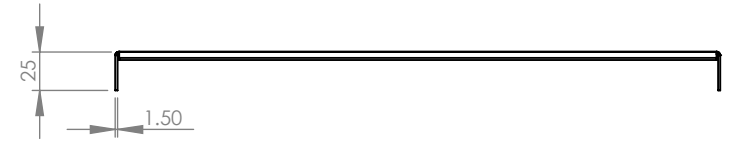
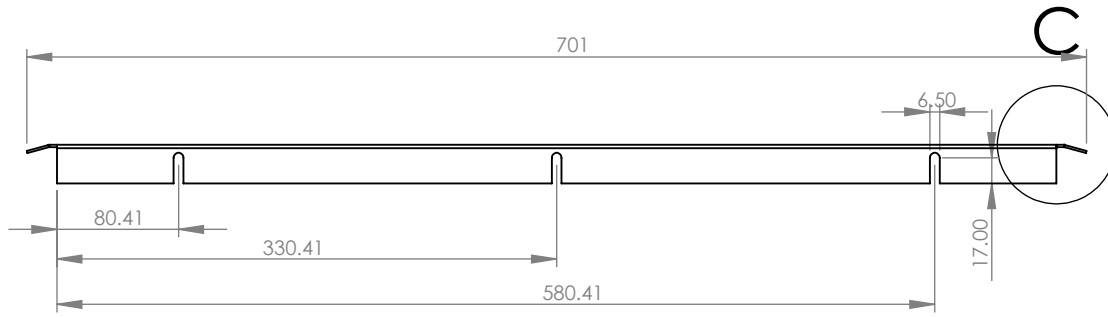

DETAIL C  
SCALE 1 : 2

Yêu cầu: Sử dụng tấm inox 201 dày 1.5mm

 <b>AKIA VIET NAM</b>				<i>Project</i>	
				<i>Drawing No.</i>	
				<i>Part name</i>	
				TẤM ĐỖ BELT 2	
				<i>Material</i>	
				SUS201	<i>Qty</i>
				<i>Scale</i>	
				1:5	1
<i>A4</i>	<i>NAME</i>	<i>SIGNATURE</i>	<i>DATE</i>		
DRAWN	K.C.Khanh				
CHEK'D	P.V.Thành				
APPV'D					

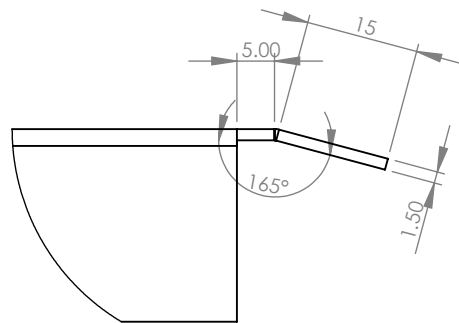
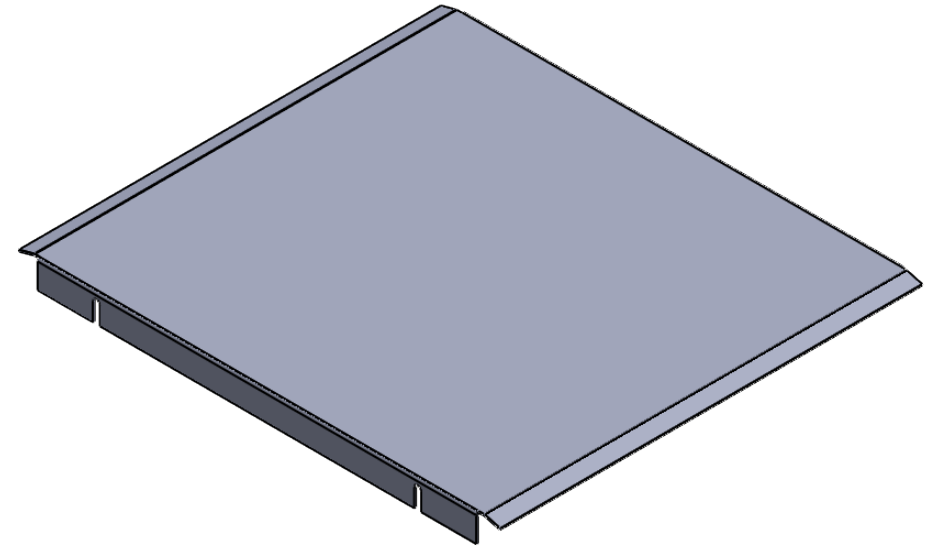
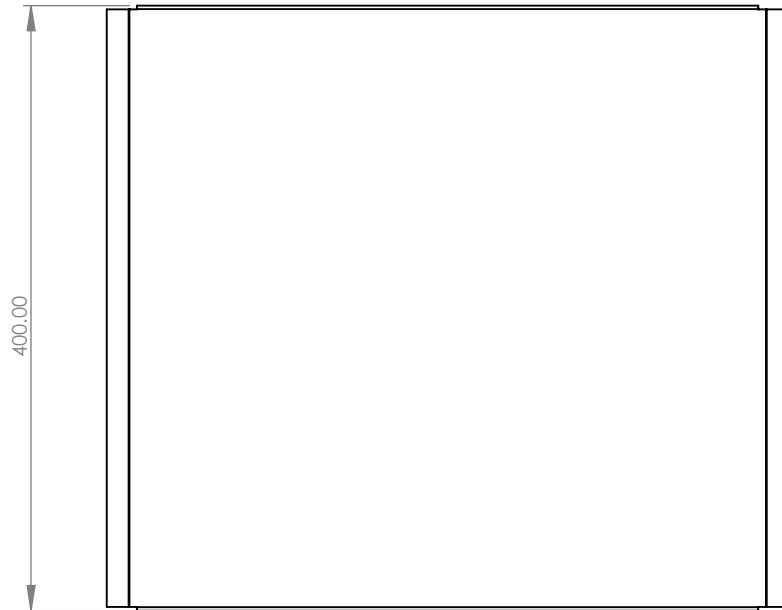
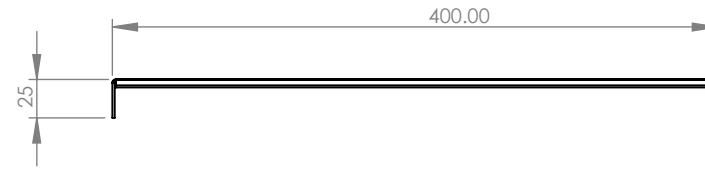
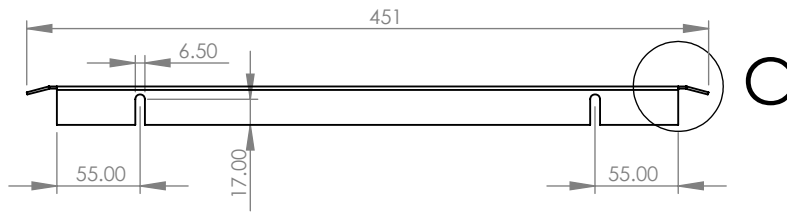

DETAIL C  
SCALE 1 : 1

Yêu cầu: Sử dụng tấm inox 201 dày 1.5mm

 <b>AKIA VIET NAM</b>				Project	
				Drawing No.	
				Part name	
				TẮM ĐỒ BELT 3	
A4	NAME	SIGNATURE	DATE	Material	Scale
DRAWN	K.C.Khanh				
CHEK'D	P.V.Thành				1:5
APPV'D					1





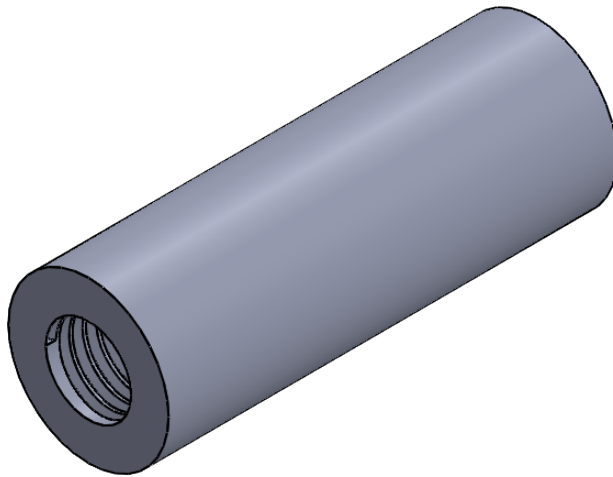
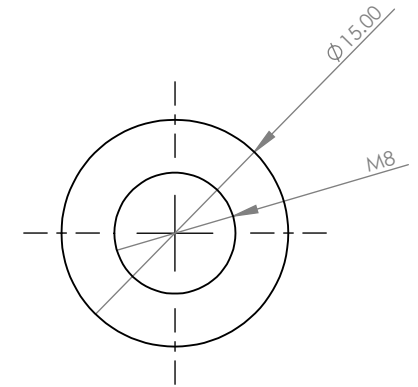
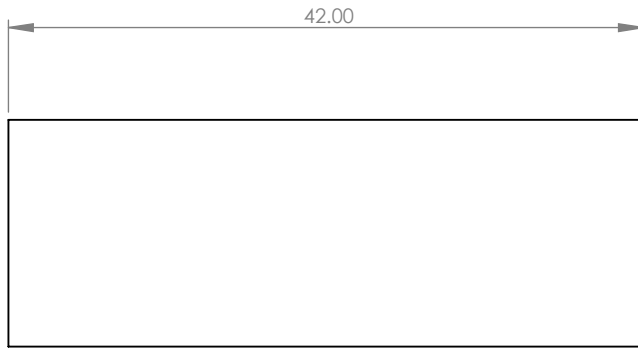

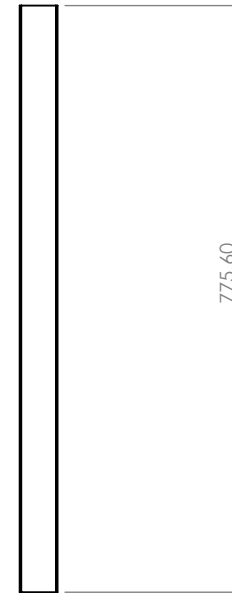
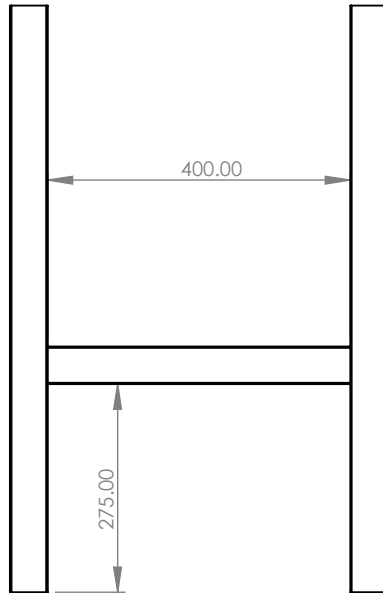

Yêu cầu:

 <b>AKIA VIET NAM</b>				Project									
				Drawing No.									
<table border="1"> <tr> <td colspan="2">Part name</td> <td colspan="2" rowspan="2">TRỤC BẮT BÍCH ĐỘNG CƠ</td> </tr> <tr> <td colspan="2">Material</td> </tr> </table>				Part name		TRỤC BẮT BÍCH ĐỘNG CƠ		Material		SS400			
				Part name				TRỤC BẮT BÍCH ĐỘNG CƠ					
Material													
<table border="1"> <tr> <td colspan="2">Scale</td> <td colspan="2">Qty</td> </tr> <tr> <td colspan="2">2:1</td> <td colspan="2">1</td> </tr> </table>				Scale		Qty		2:1		1			
				Scale		Qty							
2:1		1											
APPV'D													



 <b>AKIA VIET NAM</b>				<u>Project.</u>	
				<u>Drawing No.</u>	
				<u>Part name.</u>	
				KHUNG CHÂN BẰNG TÀI	
<u>A4</u>	<u>NAME</u>	<u>SIGNATURE</u>	<u>DATE</u>	<u>Material.</u>	<u>Q.ty</u>
DRAWN	K.C.Khanh			THÉP HỘP 50X50	
CHEK'D	P.V.Thành				
APPV'D				Scale 1:10	1

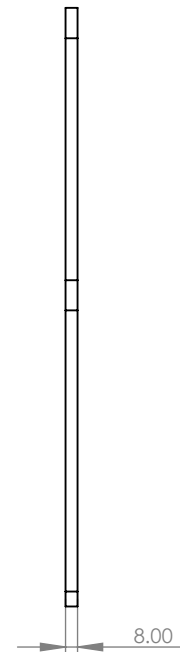
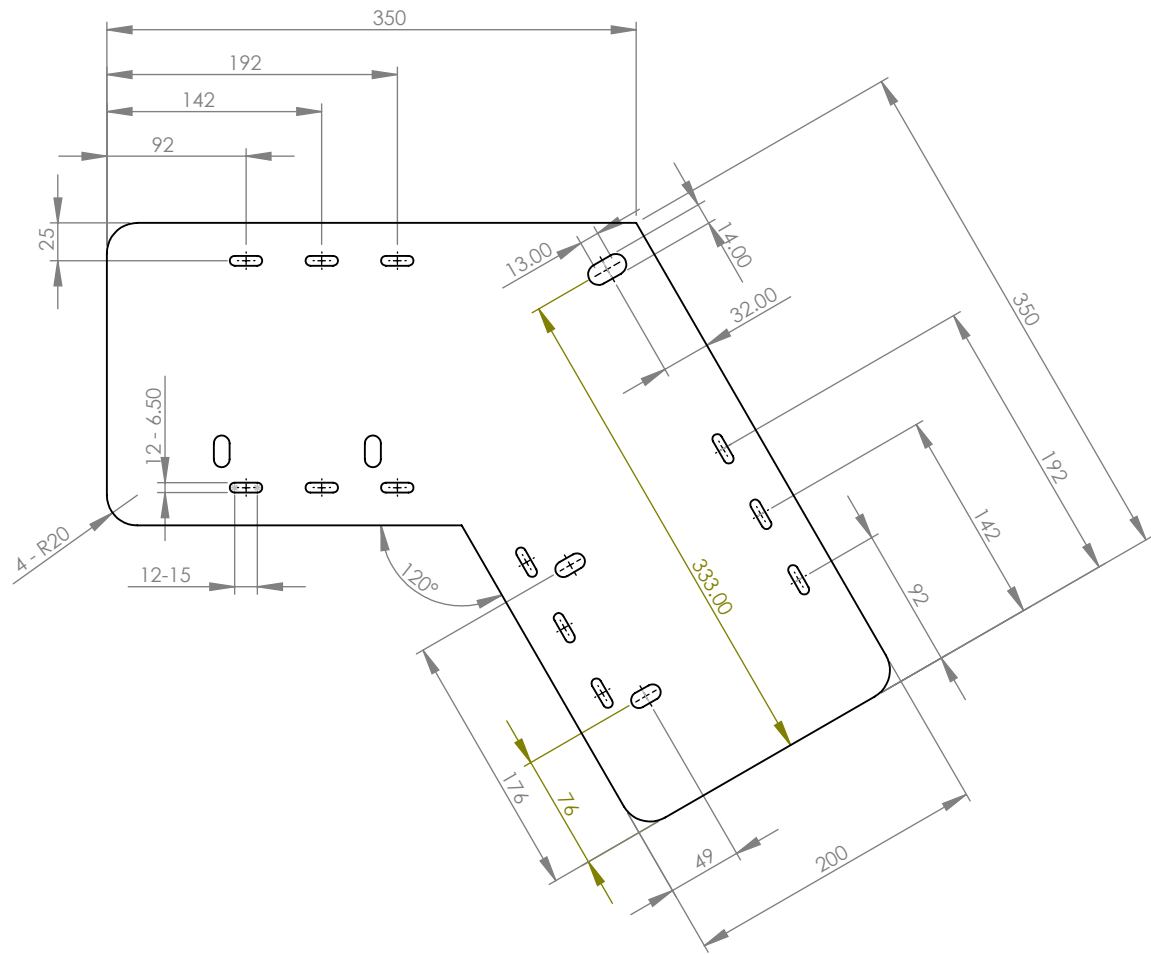

Yêu cầu:

 <b>AKIA VIET NAM</b>				Project									
				Drawing No.									
<table border="1"> <tr> <td colspan="2">Part name</td> </tr> <tr> <td colspan="2" style="text-align: center;"><b>BÍCH NỐI CỤM KHUNG 1</b></td> </tr> </table>				Part name		<b>BÍCH NỐI CỤM KHUNG 1</b>		Material					
				Part name									
<b>BÍCH NỐI CỤM KHUNG 1</b>													
<table border="1"> <tr> <td colspan="2" style="text-align: center;">SS400</td> <td colspan="2" style="text-align: center;">Qty</td> </tr> <tr> <td colspan="2" style="text-align: center;">Scale 1:5</td> <td colspan="2" style="text-align: center;">2</td> </tr> </table>				SS400		Qty		Scale 1:5		2			
				SS400		Qty							
Scale 1:5		2											
A4		NAME	SIGNATURE	DATE									
DRAWN		K.C.Khanh											
CHECK'D		P.V.Thành											
APPV'D													

